

PLEASE READ THESE INSTRUCTIONS IN THEIR ENTIRETY BEFORE COMMENCING INSTALLATION.

LOCATION SELECTION

1. Choose an open position clear of major obstructions (such as metal grab-rails) to reduce signal shadowing and improve the achievable range.
2. Consider the cable routing and distance to the equipment. Flexing of the antenna during vessel motion will place stress on the mounting point, so select a sound, rigid and ideally flat surface.
3. Verify that it is safe to drill through the desired location (e.g. no electrical wiring).
4. If intending to 'angle' the antenna flat when not in use, ensure the whip is free of obstructions when folding.

INSTALLATION

1. Use the base to mark out where the four (4) screw holes are to be drilled.
2. Drill each of the four (4) retention holes
3. Drill single (1) cable hole to size, in a suitable location.

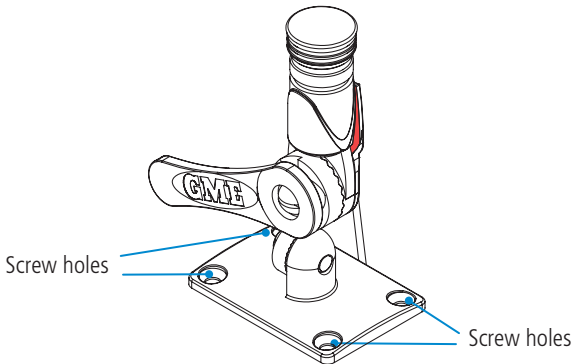

4. The ABL016 is supplied with 3 colour coded plastic tabs, Red* (27MHz), Green (VHF) and Yellow (AM/FM), choose the tab that suits the whip and radio you are connecting the antenna base to.

Prior to inserting tab, set the antenna handle by adjusting the screw passing through the handle, once set tighten handle so it is firm.

To insert the tab, loosen the nut on other end of bolt, use a screw driver to ensure that the handle does not loosen. A gap will appear on the side that the antenna cable enters into the base.

Slide the tab into the gap, ensuring it has slotted in correctly. Tighten the nut whilst keeping a screwdriver in the other end so that the handle does not loosen, then tighten the nut until the tab is held in place securely.

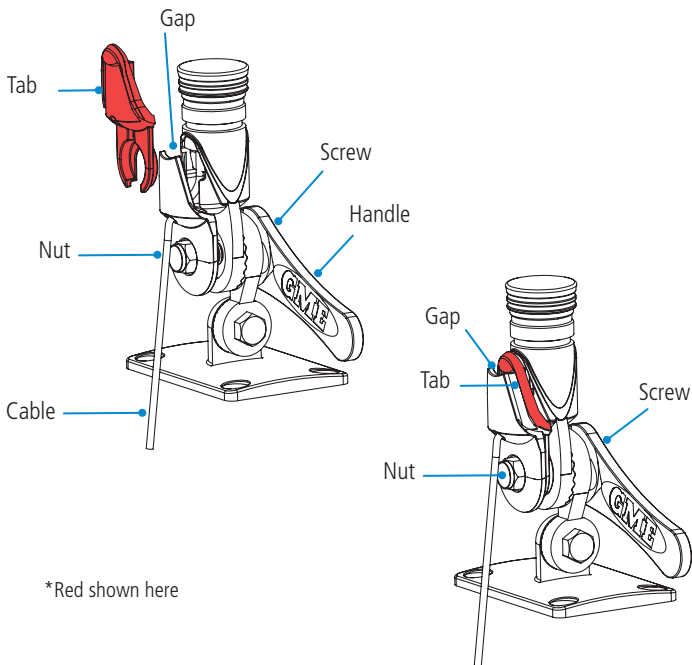

*Red shown here

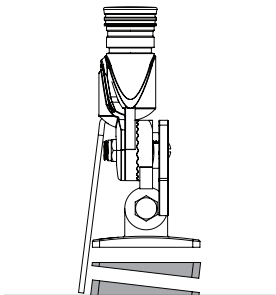
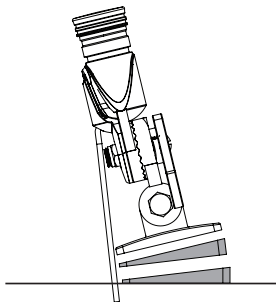
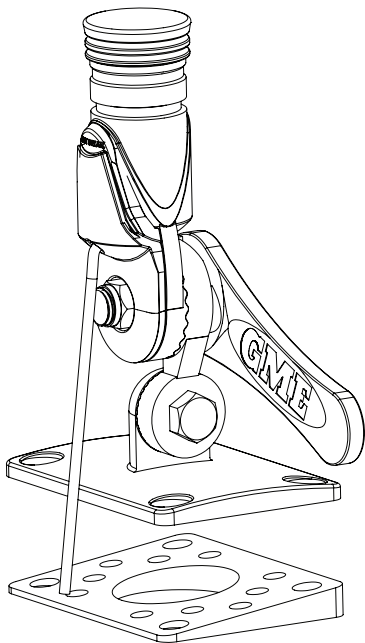

5. To optimise seal, apply a bed of neutral cure silicon sealant under the bottom of the base. Slope adjusting wedges have been provided to alter the angle/height. Fit as required.
6. Firmly secure the four (4) retention screws. Do not over tighten, it is better to check and further tighten after approximately one (1) month of use.
7. Finally, route the remaining cable to the radio equipment.

NOTE: It is recommended not to cut or shorten the supplied cable.

IMPORTANT: Longer cable runs, please contact your GME dealer for the appropriate GME extension cable.

WARRANTY

1. STATUTORY WARRANTIES

- 1.1 The Trade Practices Act Part V, Division 2A and other legislation imply conditions, warranties and other obligations on us to consumers that cannot be excluded, restricted or modified. Those provisions apply to the extent required by law.
 - 1.2 We exclude all other conditions, warranties and obligations which would otherwise be implied concerning the activities covered by this agreement.
 - 1.3 We limit our liability where we are allowed to do so. Examples of where we are allowed to limit liability are -
 - (a) you acquire goods from us for re-supply;
 - (b) the goods or services we supply are not of a kind ordinarily acquired for personal, domestic or household use or consumption.
 - 1.4 Where we are allowed to limit our liability, to the extent permitted by law, our sole liability for breach of a condition, warranty or other obligation implied by law is limited -
 - (a) in the case of goods we supply, to any one of the following as we decide -
 - (i) the replacement of the goods or the supply of equivalent goods;
 - (ii) the repair of the goods;
 - (iii) the payment of the cost of repairing the goods or of acquiring equivalent goods;
 - (iv) the payment of the cost of having the goods repaired; or
 - (b) in the case of services we supply, to any one of the following as we decide -
 - (i) the supplying of the services again;
 - (ii) the payment of the cost of having the services supplied again.
- replace goods which we are satisfied are defective. We warrant replacement parts for the remainder of the period of warranty for the goods into which they are incorporated.
- 2.3 We warrant our other repairs to be free from defects in materials and workmanship for three months from the date of the original repair. During this period and as our sole liability to you for the repair, we agree to repair or replace (at our option) repaired goods which we are satisfied are defective.
 - 2.4 We warrant that we will perform services with reasonable care and skill and agree to investigate any complaint made in good faith that we have performed services unsatisfactorily. If we are satisfied that the complaint is justified, and as our sole liability to you under this warranty, we agree to supply those services again at no extra charge to you.
 - 2.5 If you want warranty service under this clause you must give us an original or copy of the sales invoice from the transaction or some other evidence showing details of the transaction.

3. OTHER LIMITATIONS

- 3.1 You may not rely on any representation, warranty or other provision by or for us which is not covered by clause [1] or repeated in this agreement in clear terms.
- 3.2 We are not liable (nor are our employees, contractors and agents) for any damage, economic loss or loss of profits whether direct, indirect, general, special or consequential -
 - (a) arising out of any breach of any implied or express term, condition or warranty; or
 - (b) suffered as a result of our negligence (or that of our employees, contractors or agents)- apart from liability as set out in the previous two clauses.
- 3.3 The liability of a party under this agreement (whether arising in contract, tort or by statute) is to be reduced by the same proportion as represents the proportion of the loss or damage caused or contributed to by the other party, its contractors or agents.

2. ADDITIONAL WARRANTIES

- 2.1 The warranties in this clause are in addition to the statutory warranties referred to in the previous clause.
- 2.2 We warrant our goods to be free from defects in materials and workmanship for one year from the date of original sale (or another period we agree to in writing). During this period and as our sole liability to you under this warranty, we agree to, at our option, either repair or



A division of: **Standard Communications Pty. Ltd.**

Head Office: Locked Bag 2086, North Ryde, NSW 1670, Australia. T: (02) 9844 6666 F: (02) 9844 6600

MELBOURNE

7 Micro Circuit,
Dandenong South, Vic. 3165
T: (03) 9798 0988
F: (03) 9798 0177

BRISBANE

Unit 1, 89-101 Factory Road,
Oxley, Qld. 4075
T: (07) 3278 6444
F: (07) 3278 6555

ADELAIDE

14 Phillips Street,
Thebarton, SA 5031
T: (08) 8234 2633
F: (08) 8234 5138

SYDNEY

Unit B, 22-24 College St.,
Gladesville, NSW 2111
T: (02) 9879 8888
F: (02) 9816 4722

PERTH

Unit 1, 10-12 Harvard Way,
Canning Vale, WA 6155
T: (08) 9455 5744
F: (08) 9455 3110

AUCKLAND

Unit 2/24 Bishop Dunn Place,
East Tamaki, Manukau NZ 2013
T: (09) 274 0955
F: (09) 274 0959

For customers outside Australia and New Zealand, please contact your local GME retailer
or email to: export@gme.net.au **www.gme.net.au**



ABLO16

To be used with the GME AW36xxx
range of detachable whips

STAINLESS STEEL BASE ASSEMBLY



INSTRUCTION MANUAL