

GME *Electrophone*

INSTRUCTION MANUAL



TX830N

26MHz TRANSCEIVER

Complies with RFS23
Type Approval No. 23/1654

**STANDARD COMMUNICATIONS
PTY. LTD.**

CONTENTS

Channel Information	2
General Description	3
Specifications	4
Operating Controls	5
Operating Instructions	6
Transceiver Installation	8
Aerial Installation	11
Warranty/Conditions	12

CHANNEL INFORMATION

Channel/Frequency Chart

CHANNEL		FREQUENCY MHz	CHANNEL		FREQUENCY MHz
OLD	NEW		OLD	NEW	
	1	26.330 AM		21	26.580 AM
	2	26.340 AM		22	26.590 AM
	3	26.350 AM		23	26.620 AM
	4	26.370 AM	8	24	26.600 AM
	5	26.380 AM		25	26.610 AM
	6	26.390 AM		26	26.630 SSB
	7	26.400 AM		27	26.640 SSB
	8	26.420 AM	10	28	26.650 SSB
	9	26.430 AM		29	26.660 SSB
	10	26.440 AM		30	26.670 SSB
2	11	26.450 AM		31	26.680 SSB
	12	26.470 AM		32	26.690 SSB
	13	26.480 AM	12	33	26.700 SSB
	14	26.490 AM		34	26.710 SSB
4	15	26.500 AM		35	26.720 SSB
		CALLING, EMERGENCY AND SAFETY			
	16	26.520 AM		36	26.730 SSB
	17	26.530 AM		37	26.740 SSB
	18	26.540 AM	14	38	26.750 SSB
6	19	26.550 AM		*39	26.760 SSB
	20	26.570 AM		*40	26.770 SSB

* These channels are shared with other services and users may experience occasional interference.

Note: AM and SSB channel allocations are recommendation only.

GENERAL DESCRIPTION

The TX830N heralds a new era in luxury AM 26MHz Citizen Band transceivers. GME Electrophone have combined superb workmanship with the latest state-of-the-art circuitry, and added features not normally found in other AM CB equipment. The TX830N is completely factory aligned and quality assurance tested to ensure maximum performance and reliability. After reading the features below, we know you'll agree the TX830N is indeed a transceiver to be reckoned with.

Advanced Features

Interference Suppressor Circuit

A selectable noise blanker coupled with an automatic noise limiter works to completely eliminate most electrical impulse type noise to give you clean clear reception.

Variable RF Gain

Fully adjustable receiver sensitivity lets you maintain reception quality even under adverse signal conditions.

Instant Channel 15 Recall

Selecting the Channel 15 Switch "IN" provides instant access to the calling channel on 26.500MHz

P.A. Function

The Public Address function turns your TX830N into a Loud Hailer for use at sporting and club meetings. (Requires external horn speaker type SPK03W).

Floating Chassis

The TX830N's chassis is isolated from the DC power connections, making it suitable for both positive and negative earth installations.

Signal Level Indicators

Three blocks of L.E.D.'s light in sequence according to the incoming signal level to indicate relative signal strength.

Power/Modulation Indicator

The L.E.D. blocks which double as received signal level indicators, also show relative power output and modulation when transmitting.

Flush Rear Panel

For ease of installation.

Rugged Front Mounted Speaker with Dust Cover

Projects the sound forward for greater clarity and lower distortion. Because less volume is required, the speaker life is significantly extended.

Full 40 Channel Operation

PLL frequency synthesised circuitry allows transmission and reception on all 40 channels of the 26MHz Citizen Band Radio Service.

Receiver Performance

The TX830N contains a sensitive and highly selective dual conversion superheterodyne receiver. A ceramic filter provides sharp selectivity and high adjacent channel rejection. As a result, transmissions on adjacent channels cause minimum interference. A very sensitive front end circuit fitted with a fully adjustable gain control ensures you receive even the weakest signals.

SPECIFICATIONS

General

Frequency Control: Phase locked loop
Frequency Range: 26.330 to 26.770 MHz
No. of Channels: 40 AM
Power Supply: Isolated Chassis 13.8 volt D.C.
negative or positive ground system.
Fuse: 2 Amp (3 AG type)
Antenna Matching: 50 Ohms. PL259 plug
Operating Temperature: 0°C to 50°C
Dimensions: 172mm (W) x 175mm (D) x 52mm (H)

Transmitter

Power Output: 4 Watts R.M.S.
Harmonic Suppression: More than -60dB
Modulation: High level class B
Frequency tolerance: Better than .001%
Power Consumption: 1.4 Amps @ full modulation

Receiver

System: Dual conversion superheterodyne
I.F. Frequencies: 1st 9.785MHz
2nd 455kHz
Sensitivity: 0.8 microvolts for 12db Sinad
Selectivity: -4dB @ \pm 6kHz
-65dB @ \pm 10kHz
Image Rejection: -85dB
Intermodulation: -50dB
Audio Output: 4.9 Watts @ 10% THD into 4 Ohms
RF Gain Control Range: 0 to 30dB
External Speaker: 8 Ohms impedance
Squelch Range: 0.6 to 20 microvolts
AGC Range: Less than 10dB change in audio
output from 2uV to 10mV R.F. input.
Power Consumption: 250mA on standby 700mA on full
audio @ 10% distortion.
Speaker: 8 Ohm, 2 Watts peak
Controls: Channel selector, volume/power
on/off squelch, RF gain
Switches: Interference suppression circuit,
CH 15, PA/CB
Connections: Microphone socket, D.C. power input
line socket, external loud speaker
socket, antenna socket,
P.A. speaker socket.

OPERATING CONTROLS

Front Panel

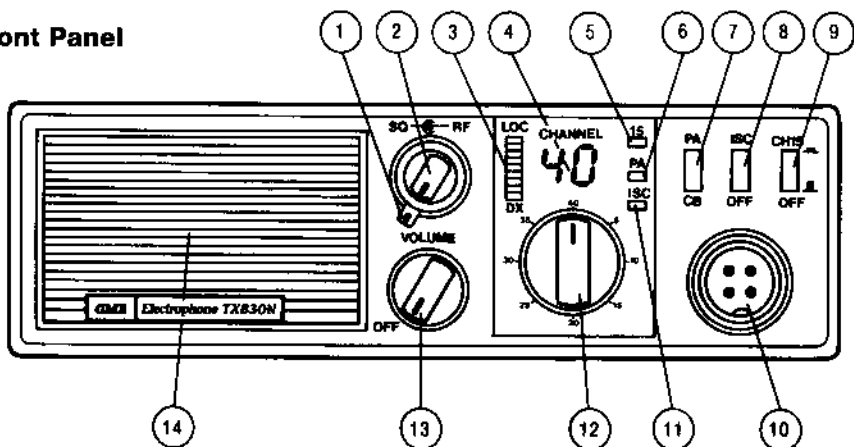

1. Squelch Control - Used to quiet the receiver during the absence of received signals.

2. RF Gain Control - Allows manual adjustment of the receiver sensitivity to suit the current reception conditions.

3. Signal L.E.D.'s - Indicate the RF output power in the Transmit mode and signal strength in the Receive mode.

4. Channel Display - Displays the currently selected channel.

5. Channel 15 L.E.D. - Lights when the Channel 15 switch (9) is selected.

6. P.A. L.E.D. - Lights when the P.A. (Public Address) mode is selected. The channel display is blank in the P.A. mode.

7. P.A./C.B. Switch - Selects the Public Address function when 'IN' and the C.B. function when 'OUT'. This switch must be OUT for normal C.B. operation.

8. I.S.C. Switch - Used to select the interference suppressor circuit when excessive electrical static is making reception difficult.

9. Channel 15 Switch - When pressed 'IN', selects the agreed calling Channel 15, (26.500MHz) and disables the rotary channel switch

10. Microphone Socket - Accepts the microphone plug. Tighten the outer ring after inserting the plug to prevent accidental withdrawal.

11. I.S.C. L.E.D. - Lights when the ISC function is selected.

12. Channel Selector - Rotate to select any of the 40 operating channels in the 26MHz C.B. band.

13. Volume On/Off Control - Rotate clockwise past the 'click' to turn the transceiver 'ON'. Continue to rotate clockwise to increase the volume level from the speaker.

14. Front Mounted Speaker - Rugged speaker with dust cover projects the sound forward for greater clarity.

15. P.A. Socket - Accepts a plug from an external 8 Ohm horn speaker (SPK03W) so that the transceiver can be used as a Public Address system or Loud Hailer. Accepts a standard 3.5mm phone plug.

16. Extension Speaker Socket - Used for connecting an external 8 Ohm to 16 Ohm speaker (SPK08). Accepts a standard 3.5mm phone plug. Inserting the plug automatically silences the inbuilt speaker.

Rear Panel

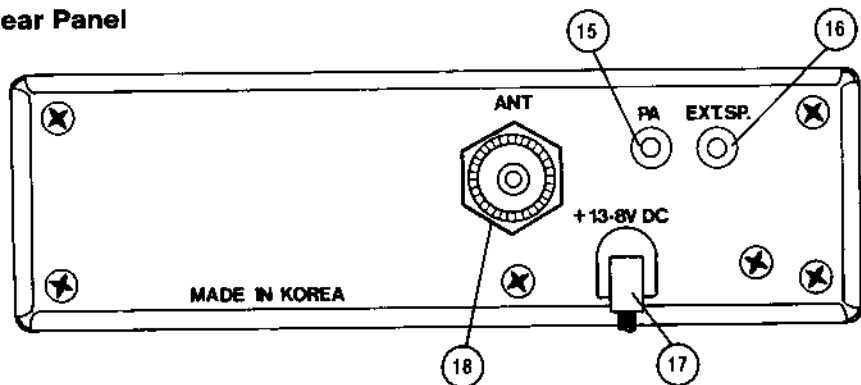

17. D.C. Power Lead - For connecting to a 13.8 Volt DC supply.

18. Antenna Connector - For connecting to a 50 Ohm antenna via the fitted SO239 type line socket. (PL259 type coaxial plug required).

OPERATING INSTRUCTIONS

IMPORTANT

NEVER ATTEMPT TO TRANSMIT WITHOUT AN ANTENNA CONNECTED TO THE TRANSCEIVER, OTHERWISE DAMAGE MAY OCCUR TO THE OUTPUT TRANSISTORS WHICH COULD VOID THE WARRANTY.

Receive Operating Procedure

1. Connect the 13.8 volt DC lead, microphone and antenna. Note: The microphone must be plugged in for the receiver to operate.
2. Ensure the PA./C.B. switch (7) is in the C.B. position ('OUT').
3. Rotate the squelch control (1) fully counterclockwise
4. Adjust the RF GAIN control (2) fully clockwise.
5. Turn the radio on using the VOLUME ON/OFF control (13) and advance the control clockwise for a comfortable volume level.

Squelch Adjustment

The squelch control is used to eliminate the background noise when there are no signals present. To adjust the squelch, turn the squelch control (1) clockwise until the background noise just disappears. At this point the receiver will be quiet under 'no signal' conditions, but an

incoming signal will overcome the squelch and be heard. As the squelch control is advanced further (from the counterclockwise position) the squelch action is progressively increased, and stronger incoming signals are needed to overcome it. To receive extremely weak signals, or to disable the squelch circuit, simply turn the control fully counterclockwise.

Selecting Channels

Rotate the channel selector switch (12) to select the required channel.

ISC Button

The TX830N contains both an automatic noise limiter and an extremely effective Interference Suppressor Circuit (ISC). The combination of these two systems will reduce and in many cases completely eliminate most impulse type electrical interference.

With the ISC button 'OUT', the Automatic Noise Limiter effectively reduces low to medium level electrical static to an acceptable level.

Where the static is excessive, making reception of signals difficult, press the ISC button 'IN'. This activates a Noise Blanker circuit which operates, along with the Automatic Noise

Limiters, to almost totally eliminate electrical interference, allowing clean reception of weak signals even under the noisiest conditions.

Channel 15 Switch

To instantly select Channel 15, press the CH15 switch 'IN'. The TX830N will immediately switch to Channel 15 and the number 15 will appear on the Channel Display. At this point, the Rotary Channel Selector Switch will be disconnected and will have no effect. Releasing the CH15 Switch will return operation to the Rotary Channel Switch.

RF Gain Control

The TX830N has a continuously variable RF Gain Control allowing the user to adjust the receiver's 'front end' sensitivity to suit the reception conditions.

When listening to weak or distant signals, the Control should be adjusted fully clockwise to give maximum sensitivity.

If receiving very strong signals, the RF Gain Control should be adjusted counter clockwise to prevent distortion caused by overload and to reduce the effects of splatter on adjacent channels. It can also be adjusted counterclockwise under congested channel conditions to help reduce many of the weaker signals allowing greater clarity of the stronger 'local' signals.

Transmitting Operating Procedure

1. Depress the Push-to-Talk Button on the microphone. The Power Modulation Indicator will light.
2. Hold the microphone 5-10cm from your mouth and slightly to one side so your voice does not project directly into the microphone. (This provides best results).
3. Speak in a normal voice. The upper section of the Power/Modulation Indicator will flash as you speak. **AVOID RAISING YOUR VOICE OR SHOUTING INTO THE MICROPHONE.**
4. When you have finished speaking, release the Push-to-Talk Button and your radio will return to the receive mode.

PA/CB Button

The P.A. feature allows the TX830N to be used as a Public Address Amplifier or Loud Hailer for

sports or club meetings. A socket (15) is fitted to the rear chassis to allow a horn speaker to be plugged in. The output level is adjusted using the volume control.

To operate as a P.A. system:

1. Connect an 8-16 Ohm horn speaker (SPK03) using a 3.5mm phone plug.
2. Select the P.A. mode by pressing the P.A./C.B. button 'IN'. The channel display will go blank and the P.A. L.E.D. (6) will light.
3. Press the microphone P.T.T. switch and speak into the microphone. Adjust the volume control for the desired output level.

Note: If a loud speaker is heard while operating in the P.A. mode, it means you are experiencing feedback.

To prevent feedback:

- (a) Keep the microphone and the loud speaker as far as possible.
- (b) Keep the microphone 'behind' the speaker - do not aim the speaker toward the microphone.
- (c) Reduce the output level by adjusting the volume control.

Receive Signal and Power/Modulation Indicators

The L.E.D. bar (3) forms a signal metering system which operates as a received signal level indicator when receiving and transmitter power output and modulation level meter when transmitting. When receiving, the L.E.D.'s light in sequence according to the signal strength received. When transmitting, the two lower sections indicate the relative power output and the upper section flashes with modulation peaks. See diagram.

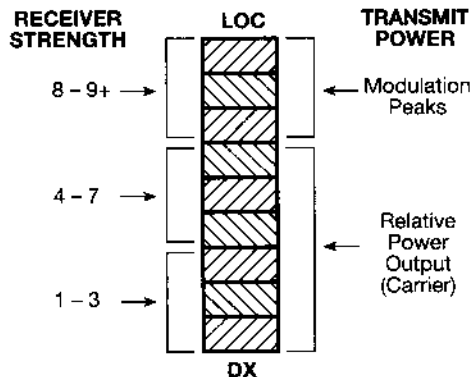

Note: If all three L.E.D. sections light when the P.T.T. is pressed, or if only one section lights, it may be an indication of poor Standing Wave Ratio (SWR) on your antenna system: In this case, check the antenna system with an SWR meter.

Ignition Noise Interference

Use of a mobile AM transceiver under low level conditions is normally limited by the presence of electrical noise. The primary source of noise in an automobile installation is the generator (or alternator) and the vehicles ignition system.

Under most operating conditions, when the signal level is adequate, the background noise does not present a serious problem. Also, when low signals are being received, selecting the ISC (Interference Suppression Circuit) switch will normally reduce or eliminate most of the electrical noise.

However, if the noise is still excessive, it may be 'getting in' to your radio by other means (e.g. power leads). If this is the case, you should contact your dealer or auto electrician for advice.

TRANSCIVER INSTALLATION

The TX830 is supplied with a Double Action Mounting Bracket with vibration proof washers. The mounting bracket can be secured to any convenient location (e.g. under the dash, above the dash, on the console, etc.).

First choose a suitable location

Always mount the radio where the controls are readily accessible. Hold the TX830N with mounting bracket in the desired position, remove the bracket, and use it as a template to

mark the location for the mounting bolts. Before drilling the holes, make sure nothing interferes with the installation of these bolts. Avoid mounting close to heaters and air conditioners.

Attach the transceiver to the bracket using the two threaded knobs and the two rubber washers as shown in figure 1. Tilt the unit to the most convenient angle before tightening the securing knobs.

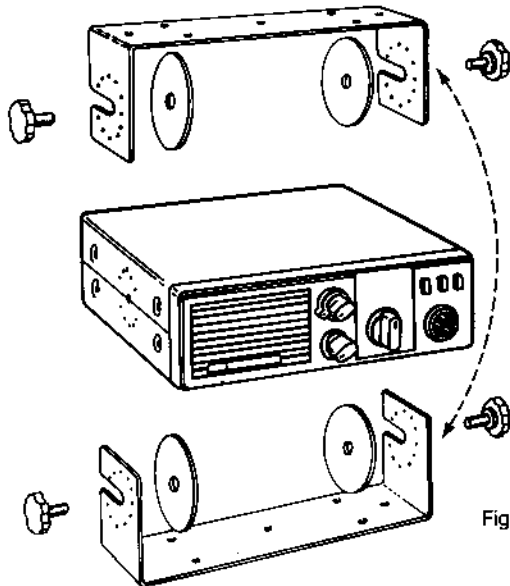

Figure 1.

DC Power Connection

The TX830N is a floating chassis design making it suitable for installation in both positive and negative earth vehicles. The transceiver is designed to operate from a voltage source of 10.5 to 15.5 Volts DC, using the fused DC cable supplied.

Negative Earth Systems (Figure 2)

Connect the Black (negative) lead to the chassis of the vehicle. The Red (positive) lead is connected to a 'live' point in the vehicles electrical system.

i.e. the Red lead can be connected to the accessory side of the ignition switch. This enables the radio to be turned 'ON' and 'OFF' with the ignition key.

Alternatively, the Red lead can be connected directly to the positive terminal of the battery. This is preferable in situations where the ignition is to switched 'OFF' but the radio is to remain 'ON'.

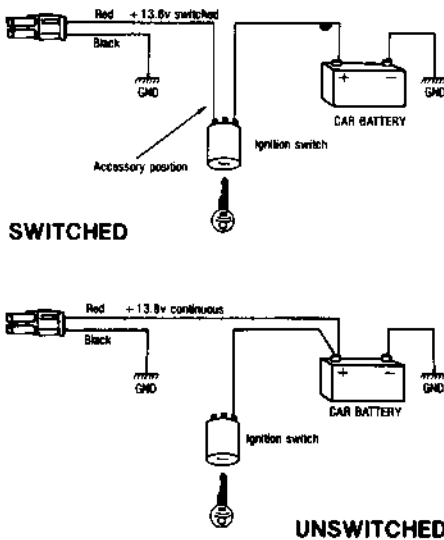

Figure 2.
Negative Earth Systems

Positive Earth Systems (Figure 3)

Connect the Red lead to the vehicles chassis. The Black lead should connect to the accessory point on the ignition switch, or alternatively to the negative terminal of the battery.

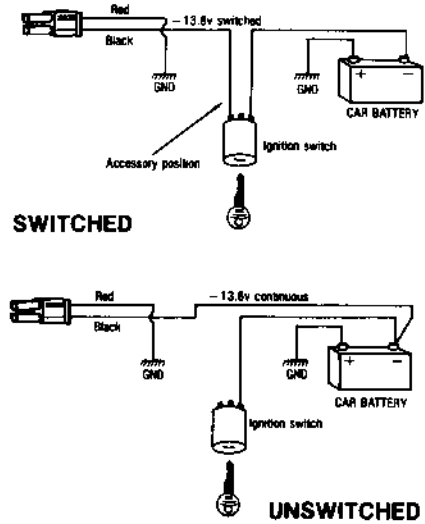

Figure 3.
Positive Earth Systems

Antenna Connection

The cable from the antenna must be terminated in a PL259 coaxial plug. Connect this plug to the matching socket on the coaxial lead extending from the rear of the set (18), and tighten the outer ring. (See the section on Antenna Installation).

AERIAL INSTALLATION

The location and installation of your antenna is entirely dependant on your vehicle type, your intended usage, and whether you are prepared to make holes in your vehicles body work. The most common methods of antenna installation are:

- (a) Centre Roof Mount
- (b) Gutter Mount
- (c) Guard Mount
- (d) Bumper Mount
- (e) Mirror Mount

Centre Roof Mount

Probably the most efficient position due to the even ground plan effect, the centre roof mount usually requires a hole to be made in the vehicles roof to accept the antenna base. Alternatively, the antenna can be mounted on a magnetic base.

Gutter Mount

The most popular method due to the ease of mounting. Performance is slightly reduced due to the uneven ground plan effect causing some directivity, however, height is maintained.

Guard Mount

Often more aesthetically pleasing, the guard mount has reduced performance over the gutter mount due to a combination of decreased height and the shielding effect of the vehicles bodywork. However, the lower mounting position allows a longer antenna to be used, alleviating some of the inefficiencies.

Bumper Mount

Usually used by 4-Wheel-Drive enthusiast due to the increased strength gained at the antenna base. Often a large spring mount coupled with a thick heavy duty flexible antenna are used to give good range and indestructibility.

Mirror Mount

Popular with truckies because of the convenient location allowing a very solid mount while keeping the antenna away from metal trailers and bodywork.

The following equipment is suitable for all types of antenna installations.



AB203

Antenna base with cable and PL259 plug – suitable for centre roof mount or mobile bracket.

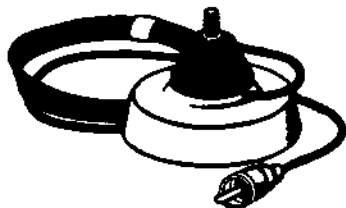

AB405

Magnetic base with cable and PL259 plug – holds firmly to any flat metal surface e.g. vehicle roof.

**MB03**

Heavy duty adjustable gutter mount bracket – suitable for deep or narrow gutters. Accepts AB203 antenna base.

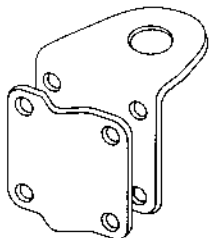
**MB401SS**

Roof rack or mirror mount bracket. Accepts AB203 antenna base.

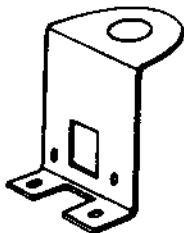
**MB407SS**

Guard Mount bracket – Attaches to bonnet or boot edge. Accepts AB203.

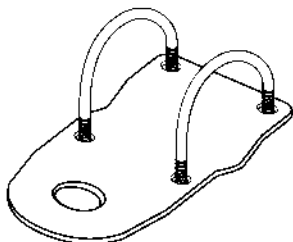
**MB408SS**

3mm Stainless Steel bull bar with Stainless Steel “U” bolts and locknuts.

**AE206N**

34cm Rubber Helical, Suitable for all mobile installations, for short range communications.

**AE214N**

1m Fibreglass Pre-tuned Helical.

AE218N

1.5m Fibreglass Pre-tuned Helical.

**AE245N (1500mm)****AE243N (1200mm)****AE242N (900mm)****AE240N (600mm)****AE240N, AE242N, AE243N, AE245N**

The “Red label” Aerials are all pre-tuned and feature copper braid with top loading coil and heavy duty PVC sheath ranging from 60cm to 1.5m.

WARRANTY

GME ELECTROPHONE limit this warranty to the original purchaser of the equipment.

GME ELECTROPHONE warrant this product to be free from defects in material and workmanship for a period of twelve (12) months from the date of purchase from their authorised dealer.

Should the product require servicing during this period, all labour and parts used to effect repairs will be supplied free of charge. GME ELECTROPHONE reserve the right to determine whether damage has been occasioned by accident, misuse or improper installation whereby the warranty would be void, including:

Transceivers which have been damaged due to:

- (a) Incorrect or reverse polarity connection to a battery or power supply.
- (b) Connection to incorrect supply voltage.
- (c) Operation without an antenna or by connection to an antenna which has been

incorrectly installed, resulting in damage to the transceiver's output transistors.

- (d) Effects of water or moisture penetration.
- (e) Non-factory modifications.
- (f) Use of incorrect replacement fuse.

Procedure to be followed by claimant: In the event of a defect occurring during the twelve (12) month warranty period, the original Purchaser may return the defective unit along with suitable proof of purchase date (i.e. receipt, docket, credit card slip etc.) and a full description of the defect to the Dealer from whom the unit was purchased.

All freight charges incurred for transportation by the Dealer or GME ELECTROPHONE are the Purchaser's responsibility.

The Dealer will forward it to the closest authorised GME ELECTROPHONE Service Depot in your particular State.

GME ELECTROPHONE AFTER SALES SERVICE

Your ELECTROPHONE transceiver is especially designed for the environment encountered in domestic or mobile installations. The use of all solid state circuitry, careful design and rigorous testing, result in high reliability. Should failure occur however, GME ELECTROPHONE maintain a fully equipped service facility and spare parts stock to meet the customer's requirements long after expiry of the warranty period.

GME *Electrophone*

A Division of
STANDARD COMMUNICATIONS PTY. LTD.

SYDNEY

6 Frank Street,
GLADESVILLE 2111
(02) 9844 6666
Fax : (02) 9844 6600

MELBOURNE

96 Voltri Street,
MENTONE 3194
(03) 9584 8099
Fax : (03) 9584 8446

BRISBANE

Unit 1, 89-101 Factory Rd,
OXLEY 4075
(07) 3278 6444
Fax : (07) 3278 6555

ADELAIDE

Unit 1/4 West Thebarton Rd,
THEBARTON 5031
(08) 8234 2633
Fax : (08) 8234 5138

PERTH

Unit 4, 43 Norma Rd,
MYAREE 6154
(08) 9330 5322
Fax : (09) 9317 1787

AUCKLAND

P.O. Box 58446
GREENMOUNT
(09) 274 0955
Fax : (09) 274 0959