



MARINE RADIO

Handheld VHF Radio

GX850W



INSTRUCTION MANUAL

CONTENTS

INTRODUCTION	3	User MMSI.....	11
CAUTION.....	3	Distress Calls	11
RF RADIATION INFORMATION.....	3	DSC MENU.....	12
OPERATING RULES.....	4	My MMSI ID Setup	13
Radio Licences.....	4	Individual Call, Position Request, Group Call and Test Call.....	13
RANGE.....	4	All Ships Call.....	15
MARINE MOBILE SERVICE IDENTITY (MMSI).....	5	Receive Call Log	16
FEATURES.....	5	Send Call Log.....	16
SUPPLIED WITH	5	Phone Book	17
OPTIONAL ACCESSORIES	5	DSC Setup.....	18
CONTROLS.....	6	MAIN MENU OPTIONS.....	18
LCD Icons.....	7	VHF Operation.....	19
KEY FUNCTIONS.....	7	GPS Setup.....	19
GENERAL OPERATION.....	8	ATIS Operation	19
Power On/Off Volume Control	8	My ATIS ID.....	20
Squelch.....	8	DSC Operation.....	21
Channel Selection.....	8	My MMSI ID.....	21
Weather Channels.....	8	LCD Backlight	21
16 Key.....	8	Backlight Time.....	21
Second Priority Channel.....	9	LCD Contrast	21
Hi/Lo Power	9	Key Beep	21
Key Lock	9	Version Info	22
Scrambler	9	Factory Reset	22
Man Over Board (MOB)	9	Charging the Battery.....	22
Backlight	9	INTERNATIONAL MARINE VHF CHANNEL AND FREQUENCIES	23
Scanning.....	9	U.S. MARINE VHF CHANNEL FREQUENCIES	25
Dual Watch.....	10	CANADIAN MARINE VHF CHANNEL AND FREQUENCIES.....	28
Triple Watch.....	10	SPECIFICATIONS	33
Time Out Timer.....	11	SC CONTRACT WARRANTY AGAINST DEFECTS	34
Displaying Time and Date	11		
Displaying Local Time.....	11		
Digital Selective Calling.....	11		
DSC and GPS	11		

INTRODUCTION

Congratulations on purchasing this GME fully featured VHF marine radio. Your GX850 has been built to offer excellent value by combining advanced features, great design and manufacturing quality. To ensure you are familiar with the operation and features of your radio, and in order to obtain the best performance, please read this manual thoroughly before operation.

CAUTION

IMPORTANT: READ ALL INSTRUCTIONS carefully and completely before operating your radio and retain this manual for future reference.

To maintain the waterproof integrity of the radio;

- **ENSURE** the antenna and the connector cover are both firmly tightened against the rubber seal (refer diagram on page 6).
- **NEVER** attempt to disassemble the radio.

NEVER: connect the radio to a power source other than the supplied battery. This may damage your product.

NEVER: operate your radio with the antenna less than 5 cm from exposed parts of the body.

NEVER: use or charge your radio in a potentially explosive atmosphere.

DO NOT: use your radio with a damaged antenna.

DO NOT: attempt to modify your radio in any way.

ALWAYS: charge your radio at normal room temperature.

ALWAYS: switch off your radio where notices restrict the use of two-way radio or mobile telephones.

AVOID: storing or charging your radio in direct sunlight.

AVOID: storing or using your radio where temperatures are below -20° C or above +60° C.

RF RADIATION INFORMATION

RF RADIATION PROFILE

Your radio is designed and tested to comply with a number of national and international standards and guidelines

(listed below) regarding human exposure to radio frequency electromagnetic energy. This radio complies with the IEEE and ICNIRP exposure limits for occupational/controlled RF exposure environment at operating duty factors of up to 50% transmitting and is authorised by the FCC for occupational use only. In terms of measuring RF energy for compliance with the FCC exposure guidelines, your radio radiates measurable RF energy only while it is transmitting (during talking in PTT mode), not when it is receiving (listening) or in standby mode.

The device complies with SAR and/or RF field strength limits of RSS-102 requirements.

RF RADIATION SAFETY

In order to ensure user health, experts from relevant industries including science, engineering, medicine and health work with international organizations to develop standards for safe exposure to RF radiation. These standards consist of:

- United States Federal Communications Commission, Code of Federal Regulations; 47CFR part 2 sub-part J;
- American National Standards Institute (ANSI)/Institute of Electrical and Electronic Engineers (IEEE) C95. 1-1992;
- Institute of Electrical and Electronic Engineers (IEEE) C95. 1-1999;
- International Commission on Non-Ionizing Radiation Protection (ICNIRP) 1998;

FCC Regulations

Federal Communication Commission (FCC) requires that all radio communication products should meet the requirements set forth in the above standards before they can be marketed in the U.S, and the manufacturer shall post a RF label on the product to inform users of operational instructions, so as to enhance their occupational health against exposure to RF energy.

Part 15 Compliance

This equipment has been tested and found to comply with the limits for a Class B digital device, pursuant to part 15 of the FCC Rules. These limits are designed to provide reasonable protection against harmful interference in a residential installation. This equipment generates, uses and can radiate radio frequency energy and, if not installed and

used in accordance with the instructions, may cause harmful interference to radio communications. However, there is no guarantee that interference will not occur in a particular installation. If this equipment does cause harmful interference to radio or television reception, which can be determined by turning the equipment off and on, the user is encouraged to try to correct the interference by one or more of the following measures:

- Reorient or relocate the receiving antenna.
- Increase the separation between the equipment and receiver.
- Connect the equipment into an outlet on a circuit different from that to which the receiver is connected.
- Consult your dealer or an experienced radio/TV technician for help.

NOTE: Changes or modifications to this unit not expressly approved by the party responsible for compliance could void the user's authority to operate the equipment.

EU Regulatory Conformance

As certified by the qualified laboratory, the product is in compliance with the essential requirements and other relevant provisions of the Directive 1999/5/EC. Please note that the above information is applicable to EU countries only.

CE06780!

OPERATING RULES

Priorities

- Read all rules and regulations pertaining to priorities and keep an up-to-date copy handy. Safety and distress calls take priority over all others.
- You must monitor Channel 16 when you are not operating on another channel.
- False or fraudulent distress calls are prohibited under law.

Privacy

- Information overheard but not intended for you cannot lawfully be used in any way.
- Indecent or profane language is prohibited.

RADIO LICENCES

Ship Station License

When your craft is equipped with a VHF FM radio, you must have a current radio station licence before using the radio. It is unlawful to operate a ship station which is not licensed. Inquire through your dealer or the appropriate government agency for a Ship-Radiotelephone license. This license includes the call sign which is your craft's identification for radio purposes.

Operators License

A restricted Radiotelephone Operator Permit is the license most often held by small vessel radio operators when a radio is not required for safety purposes. The restricted Radiotelephone Operator Permit must be posted near the radio or be kept with the operator.

Only a licensed radio operator may operate a radio. However, non-licensed individuals may talk over a radio if a licensed operator starts, supervises, ends the call and makes the necessary log entries.

A current copy of the applicable government rules and regulations is only required to be on hand for vessels in which a radio telephone is compulsory. However, even if you are not required to have these on hand it is your responsibility to be thoroughly acquainted with all pertinent rules and regulations.

RANGE

The range of VHF transmissions depends on antenna height, transmitter power and the terrain over which the signals pass. For a 5 watt handheld radio like the TX850, ship to ship communications up to 5 nautical miles should be possible. Using an external antenna should allow ship to ship communication of 8 nautical miles or more. Ship to shore ranges will often be greater due to the increased height of the shore antenna.

MARINE MOBILE SERVICE IDENTITY (MMSI)

The MMSI is a 9-digit number used to identify a radio that is capable of using Digital Selective Calling (DSC). The number is used to selectively call other vessels. To setup and use the DSC feature on your radio: Please refer to the 'DSC' section of this manual.

USER MMSI

To use the DSC feature you must be registered with the appropriate licensing authority (AMSA in Australia) who will issue you with your unique user MMSI number. Having a registered user MMSI means you can be identified much quicker in an emergency. Once you have obtained your MMSI number you can then enter this into your GX850 to enable DSC operation. Your GX850 is shipped from the factory without a user MMSI number. It is up to the user to obtain a valid MMSI from the appropriate licensing authority.

NOTE: If you don't register for a User MMSI, you can still receive DSC distress calls from other vessels however you cannot send a DSC call.

GROUP MMSI

The Group MMSI is used for DSC Group Calls. A Group Call provides a method for contacting a group of vessels with a common interest, for example, alerting all yachts in a race to announce a change in the race conditions. Any number with a leading zero can be used as a Group MMSI, and they do not need to be registered, but the entity deciding on a Group MMSI must use the MID of the host country or country of vessel registration (e.g. 503 in Australia). The Group ID should be based on a key vessel in the Group, and the recommended system is to drop the last digit of the key vessel's MMSI and place a zero in front.

For example, a fleet of vessels that has a lead vessel with a DSC User MMSI of 503080110 could use the Group MMSI of 050308011. This would then be programmed into all fleet vessels as the special event Group MMSI.

See 'My MMSI ID Setup' on page 13 for details on entering a group MMSI.

FEATURES

- Waterproof to IP67
- Man Overboard Alarm Function
- Floats with Auto-Flashing LCD if dropped overboard
- Integrated 48 Channel GPS Receiver
- 5/1 watt Switchable Power
- Large Dot-Matrix LCD
- Private Channel Facility
- Programmable Scan, Priority Scan, Dual and Tri Watch
- All International, US and Canadian Marine VHF Channel Sets.
- Integrated 1700 mAh Lithium Polymer Battery

SUPPLIED WITH

- GX850 DSC Marine Radio
- Belt Clip
- 240V AC Charger
- Wrist Strap
- High Gain Flexible Antenna
- Instruction Manual

OPTIONAL ACCESSORIES

- MB046 – Belt Clip
- PSK20P – Plug Pack for 9V1A Prop Conn
- AE4024 – Flexible Antenna
- CSGX850 – Cap and Seal

CONTROLS

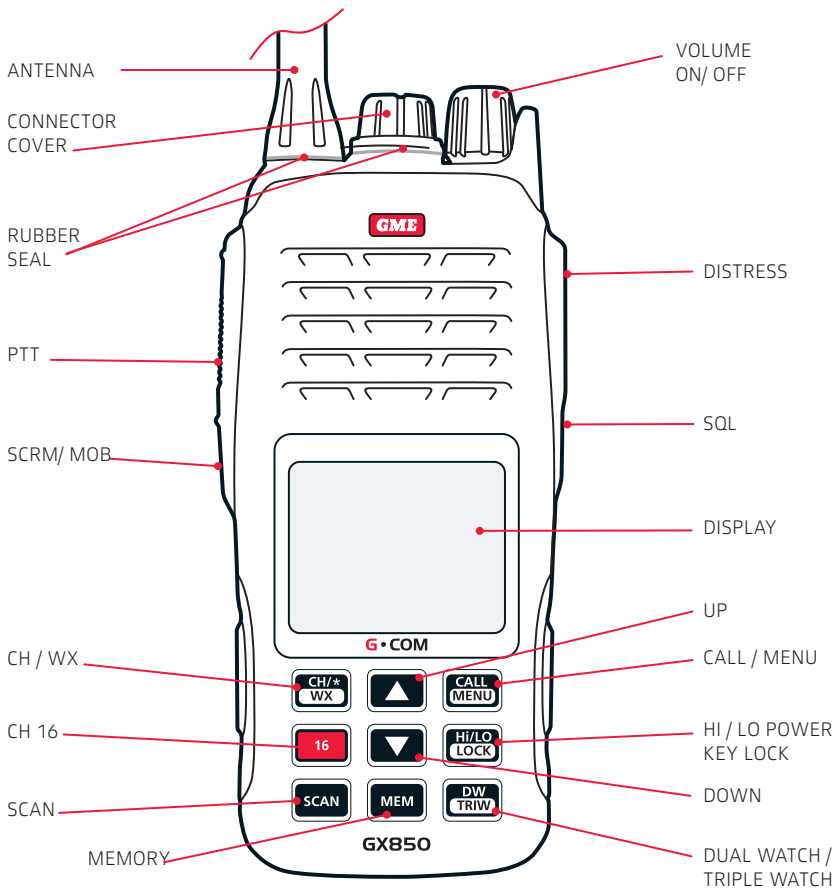

LCD ICONS

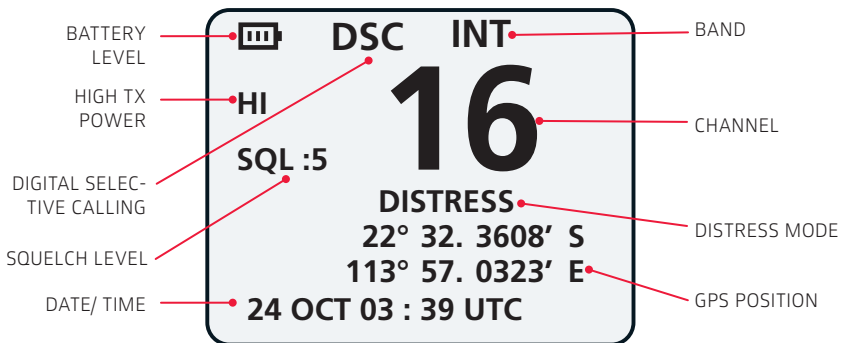

KEY FUNCTIONS



KEY	SHORT PRESS	LONG PRESS
Hi/LO [LOCK]	Transmit Power Hi/Low	Key Lock / Key Unlock
16	CH 16	Secondary Priority channel
DW [TRIW]	Dual Watch Mode	Triple Watch mode
CH/* [WX]	Private Channel	Weather channel
SCAN	Scan	Priority Scan
MEM	Memory Mode	Save/Delete Memory channel
Up/ Down	Channel Up/Down	Fast Up/Down
Call/ Menu	DSC Menu	Main Menu
SCRM/MOB	Scrambler	MOB Activated
Distress	Distress Menu	Distress Alert Calling
SQL	Squelch Setting	Switch ON/OFF Time and Date Display
Volume Knob	Power ON / OFF. Adjust the Volume Level	

GENERAL OPERATION





POWER ON/OFF VOLUME CONTROL

Turn the Volume knob clockwise past the 'click' to turn the radio ON. Continue turning the knob clockwise to increase the volume. Turn the knob counter-clockwise to reduce the volume. Continue turning the knob counter clockwise past the 'click' to turn the radio OFF.

SQUELCH





To adjust the Squelch, briefly press the **SQL** key. The present squelch level will be displayed. Use the  or  keys to adjust the squelch level from 0 (min) to 9 (max).

CHANNEL SELECTION

Briefly press the  key to step upwards one channel or the  key to step downwards one channel. Press and hold the  or  keys to scroll quickly through the channels at a faster rate. When the key is released the channel scrolling stops.

WEATHER CHANNELS (USA & CANADIAN CHANNEL SET)

The US NOAA weather channels are available only when the USA or Canadian Channel Set is selected. Weather channels are not available on the International marine band.

To access the weather channels while on the USA or Canadian band, press and hold the  key. The radio will switch to the weather channels and the 'WX' icon will appear. Weather channels are numbered 01 – 10 and are selected using the  or  keys. To return to the normal communications channels press and hold the  key again.





NOTE: Weather channels provide a receive-only weather information service in and around the USA and Canada. You cannot transmit on the weather channels.

Weather Alert Operation (WAT) (USA & Canada)

When a weather warning is issued in your area the NOAA weather service will transmit a weather alert tone on your local weather channel. If the weather alert function is activated on your radio, the reception of this tone will cause a short alarm to sound and the radio will automatically tune



to the weather channel where the alert tone was detected. The alert should be detected in all the modes of operation including Standby, Dual and Tri-watch and Scan etc.

To Activate the Weather Alert Function

1. Press and hold the  key to select the weather channels. 'WX' is displayed.
2. Press and hold the  key again to switch ON the weather alert function. 'WAT' will appear in the upper right of the display.
3. Select the local weather channel that you wish to monitor for alerts using the  or  keys.
4. Briefly press the  key to return to normal operation.

When the weather alert function is enabled the radio will check the selected weather channel every 4 seconds for a weather alert tone. If an alert tone is detected, the 'WX' and 'WAT' icons will flash and a short alarm tone will sound. The radio will then automatically switch to the selected weather channel to allow you to hear the weather warning.

To disable weather alerts;

1. Press and hold the  key to enable the weather channels. 'WX' is displayed.
2. Press and hold the  key again to switch OFF the weather alert function. 'WAT' will disappear from the upper right of the display.
3. Briefly press the  key to return to normal operation.



Private Channels

A brief press of the  key is for private channels. This feature is not available to users in Australia and New Zealand.



16 KEY

The GX850 supports two priority channels.

Priority Channel 16

Briefly press the  key to switch to Channel 16. All previous functions such as scanning or low power will be cancelled and the radio will switch to channel 16 with Hi transmit power selected. When the  key is used to select





channel 16, 'P-CH' is displayed.

Briefly press the  key again to return to the last selected channel or to go to an alternative channel press the  or  keys.

SECOND PRIORITY CHANNEL

Programming the Second Priority Channel

The second priority channel can be preset through the main menu (see menu section) or can be changed directly from the display as follows.

1. Press and hold the  key to switch to the second Priority channel. 'P-2nd' is displayed.
2. Press and hold the  key again. 'Set 2nd Prior CH' is displayed and the channel number flashes.
3. Use the  or  keys to select a new channel.
4. Press and hold the  key to store the new channel as the second priority channel.



NOTE: Priority channel 16 is factory set and cannot be changed.



HI/LO POWER

Briefly press the  key to toggle high or low transmitter power. The display will show 'Hi' or 'Lo' to confirm the selected power setting.

NOTE: Some channels may be permanently set to Hi or Lo power by default. If any of these channels are selected you will not be able to change the power setting for that channel.





KEY LOCK

Press and hold the  key to lock the keypad. The  icon will be displayed when the keypad is locked and all keys except the **PTT** and any Distress related keys will be locked.

To unlock the keypad, press and hold the  key again. The  icon will disappear.

SCRAMBLER

Your radio incorporates a simple voice scrambler that, when activated, will make your signal intelligible only to other radios using the same scrambler technology.

- To activate the Scrambler, briefly press the  key.  will appear on the display.
- To disable the Scrambler, briefly press the  key again.  will disappear from the display.

MAN OVER BOARD (MOB)

The MOB function is designed to automatically send a MOB distress call with your MMSI and latitude and longitude.

To activate the MOB function, press and hold the  key for 2 seconds.

NOTE: In order to make DSC distress calls including MOB calls you must have your user MMSI programmed into your radio.

BACKLIGHT

The backlight operates automatically whenever any key (except the **PTT**) is pressed and switches off about 7 seconds after the last keypress. The backlight provides lighting for the display, keypad and Distress button.

Water Activated Backlight Alert

If the GX850 is immersed in water, sensors built into the case will cause the backlight to flash urgently. This feature is designed to make it easier to locate and recover your radio if it is accidentally dropped into water.

SCANNING

Basic Scan

The basic scan function allows the radio to scan all channels for transmissions. When a signal is detected the scan pauses to allow the signal to be heard. Once the signal has gone the scan resumes.

To activate the scan function, briefly press the  key. 'SCAN' appears on the display and the channel numbers change rapidly.

To deactivate the scan function, briefly press the  key again. 'SCAN' disappears from the display.

Priority Scan

Priority scan is similar to the basic scan except it regularly inserts channel 16 into the scan. Signals received on channel 16 have priority over signals received on other channels.

To activate the Priority scan function, press and hold the **SCAN** key. 'SCAN' appears on the display and the channel numbers change rapidly with channel 16 appearing predominantly in the channel display area.

To deactivate the Priority scan function, briefly press the **SCAN** key. 'SCAN' disappears from the display.

User Memory Scan

User Memory Scan allows you to program a select group of channels for scanning.

To Program User Memory Channels

1. Use the **▲** or **▼** keys to select the required channel.
2. Press and hold the **MEM** key. The **M** icon appears to the right of the selected channel number to confirm the channel is in Memory.
3. Repeat steps 1 and 2 to add further channels to the User Scan Memory.

NOTE: Separate User Memories can be stored for USA, International and Canadian bands.

To Activate the User Memory Scan

1. Briefly press the **MEM** key. 'USER' appears to the left of the channel display indicating the radio is now in User Memory mode and the channel number switches to a User Memory channel (only User Memory channels are displayed while in User mode).
2. Briefly press the **SCAN** key. The radio will begin scanning the User Memory channels.
3. To stop scanning; briefly press the **SCAN** key.
4. To exit the User Channel mode, briefly press the **MEM** key. 'USER' will disappear from the display and the radio will return to the last selected channel.

Reviewing User Memory Scan Channels

To quickly determine which channels are stored in the User Memory;

1. Briefly press the **MEM** key. 'USER' appears to the left of the Channel display.
2. Press the **▲** or **▼** keys to quickly to step through the

Memory Scan channels. Only channels stored in Memory Scan will be displayed.

3. To exit Memory Scan, briefly press the **MEM** key. 'User' will disappear from the display.

NOTE: You cannot add or remove channels from the User Memory Scan while in the User mode. You must exit the User mode to edit User Memory channels.

DUAL WATCH

The Dual Watch function is a 2 channel scan feature where the radio switches between Channel 16 and any other selected channel. This allows you to monitor a working or club channel while still being able to receive important broadcasts on Channel 16.

To use the Dual Watch function:

1. Use the **▲** or **▼** keys to select your preferred working channel.
2. Briefly press the **DW** key to activate Dual Watch.

'DUALW' will be displayed and the channel number will quickly alternate between 16 and the selected channel as the radio monitors both channels.

If a signal is received on the selected channel, the Dual Watch will pause to allow the signal to be heard but will continue to monitor channel 16 every 2 seconds resulting in short breaks in the conversation. Once the signal has gone, Dual Watch continues.



If a signal appears on channel 16 it will take priority over any signals on the selected channel.

TRIPLE WATCH

The Triple Watch function is a 3 channel scan feature where the radio switches between Channel 16, a selected channel and the second priority channel. This allows you to monitor 2 channels while still being able to receive important broadcasts on Channel 16.

NOTE: Prior to using Triple Watch ensure you have programmed your second priority channel.

To use the Triple Watch Function

1. Use the  or  keys to select your preferred working channel.
2. Press and hold the  key to activate Triple Watch. 'TRIW' will be displayed and the channel number will quickly switch between 16, the second priority channel and the selected channel.

If a signal is received on the either selected channel or the second priority channel, the Triple Watch will pause to allow the signal to be heard but will continue to monitor channel 16 every 2 seconds resulting in short breaks in the conversation. Once the signal has gone, Triple Watch continues.

If a signal appears on channel 16 it will take priority over any signals on the other channels.

TIME OUT TIMER

The radio has a built-in time out timer that automatically limits transmissions to a maximum of 5 minutes of continuous operation. This feature is required to prevent accidental blocking of the frequency should your **PTT** become jammed or be otherwise pressed accidentally.

When the time out timer activates, the transmission will stop, and the radio will return to receive mode. Normal operation will be restored once the **PTT** is released.

DISPLAYING TIME AND DATE

When the GX850 is not receiving GPS signals, the screen will display the time and date.

To switch the time and date display on or off, press and hold the **SQL** key for 3 seconds.

DISPLAYING LOCAL TIME

GPS time is received from the satellites in UTC format. To display the time as local time please refer to the GPS Setup option on page 19.

DIGITAL SELECTIVE CALLING

The Digital Selective Calling (DSC) feature on your GX850 uses preformatted digital data messages instead of voice to transmit urgent or important information to another radio. In times of an emergency, DSC can alert all radios within range

to a distress message even when a listening watch is not being maintained. This increases the chances of your signal being heard. DSC can also be used to make All Ships Calls, Group Calls and Position Requests as well as routine calls to individual radios.

DSC is part of the Global Maritime Distress and Safety System (GMDSS) which is expected to eventually replace listening watches on distress frequencies and will be used to announce all routine and urgent maritime safety information broadcasts.

DSC AND GPS

DSC operation is enhanced by the in-built GPS receiver in your GX850. By using GPS, your distress call can automatically include your current position and time. If a GPS position cannot be obtained, DSC calls can still be sent and received to alert the operator of another vessel for subsequent voice communication.

DSC calls are automatically sent and received on CH70. The GX850 has two receivers, one of which is dedicated to CH70. Therefore, regardless of which channel you are operating on, the GX850 will not miss a DSC call.

USER MMSI (MARINE MOBILE SERVICE IDENTITY)

A User MMSI is a unique 9-digit number used to identify a DSC capable radio. An MMSI is used to selectively call other vessels. Before you can use DSC, you must enter your User MMSI number into the 'My MMSI ID' option in the DSC Menu. If you don't yet have a User MMSI, please register with your local Maritime Authority (AMSA in Australia - go to <http://www.amsa.gov.au/mmsi/> for more details and to download an application form) who will then issue a unique MMSI number. Please refer to the 'My MMSI ID' option further below for instructions on entering your User MMSI.

DISTRESS CALLS

To make a Distress Call use the button under the Red **DISTRESS** cover on the side of the GX850. To make any other DSC call, use the  key on the main keypad.

Making a Distress Call

1. Lift the bottom of the Red DISTRESS cover on the side of the radio.

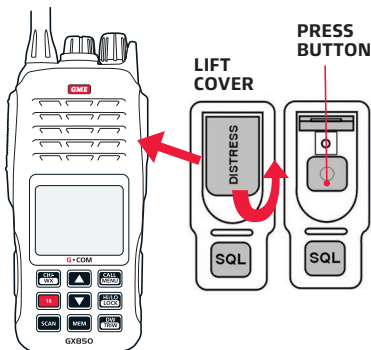

- Briefly press the **DISTRESS** button. The display shows the 'Distress' Menu list.

Distress Menu
 Undesignated
 Fire, Explosion
 Flooding
 Collision
Grounding
 Capsizing
 Sinking
 Exit ▲▼

- Use the ▲ or ▼ keys to select the nature of the distress. The list includes: Undesignated, Fire, Explosion, Flooding, Collision, Grounding, Capsizing, Sinking, Adrift, Abandoning, Piracy and Man Overboard.
- Press and HOLD the **DISTRESS** button. The display will flash and the radio will count down from 3 to 1.

NOTE: To cancel the distress call, release the **DISTRESS** button before the countdown is completed. The radio will return to normal operation.

When the countdown is complete, the **DISTRESS** call will be sent. The radio will then switch to CH16 and the display will show 'DISTRESS' to indicate it is now in the distress mode and is waiting for an acknowledgement from another radio. The distress call mode will be cancelled when a **DISTRESS ACKNOWLEDGE** is received. The radio will then return to normal operation.

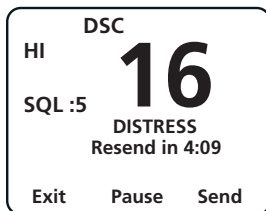

If an acknowledgement is not received, the distress call will be re-sent at around 4 minute intervals for as long as the radio remains in the distress call mode. Select **PAUSE** to delay the resending of the distress call or **SEND** to resend the call immediately. To cancel the call select **EXIT**.

NOTE: A Distress Acknowledge response is generally sent by a coastal base station.

Receiving a Distress Call

When a Distress Call is received an audible Distress Alert alarm will be generated and, if the Auto Channel Change in the DSC Setup Menu set to Automatic, the GX850 will switch to CH16.

To see all received DSC messages, press the **CALL MENU** key and select the Receive Call Log then press Enter.

DSC Menu
 Individual Call
 Position Request
 All Ship Call
 Group Call
 Test Call
Receive Call Log
 Send Call Log
 Exit ▲▼ Enter

DSC MENU

Apart from distress calls, all other DSC calls are made using the Menu available from the **CALL MENU** key. To access the DSC menu briefly press the **CALL MENU** key. The following menu will appear.

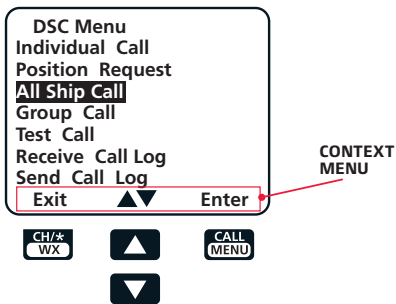

Note the context menu options at the bottom of the display. Press the keys directly below the context menu to select those options. E.g. In the example above, press the **CH/↕ WX** key to Exit the menu, the **▲** or **▼** keys to move up and down through the menu items and the **CALL MENU** key to Enter (select) the menu item.

The following Menu items are available:

- Individual Call
- Position Request
- All Ship Call
- Group Call
- Test Call
- Receive Call Log
- Send Call Log
- Phone Book
- DSC Setup
- My MMSI ID

MY MMSI ID SETUP

Before using the DSC function you must set up your user MMSI ID. If you don't yet have a User MMSI, please register with your local Maritime Authority.

NOTE: The reception of distress calls does not require a user MMSI.

IMPORTANT: It is a requirement of the regulations that the User MMSI can only be entered ONCE. For this reason take special care when entering your user MMSI number to ensure it is entered correctly before saving it. You will be required to enter your MMSI twice as confirmation of the correct number before it is stored by the radio. If you need to change the MMSI (due to an entry error or after purchasing a second hand GX850) please contact GME to arrange for the MMSI code to be reset.

To enter the 9 digit User MMSI number issued to you by your local authority:

1. Briefly press the **CH/↕ WX** key to enter the DSC menu.
2. Press the **▼** key to scroll down the screen until 'My MMSI ID' is selected then press Enter.
3. Use the **▲** or **▼** keys to select the number in the first digit position then press **▶**.
4. Repeat step 3 to enter the full 9 digit MMSI number.
5. Once all 9 digits have been entered you will be asked to enter them again.
6. Repeat step 3 to re-enter the MMSI then press **Enter** to store or **Exit** to cancel without saving.

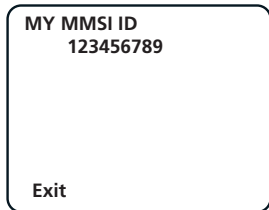

INDIVIDUAL CALL, POSITION REQUEST, GROUP CALL AND TEST CALL

The '**Individual Call**' option is used to alert a specific vessel that you wish to communicate with them on a specified channel. If the called vessel's radio is on a different channel, their radio will change to the channel you specify.

A '**Position Request**' (or position polling) is used to obtain the position of another vessel. If the receiving vessel is in range, an acknowledgement will be received from them that will include their position. If there is no acknowledgement, either the receiving boat is not in your communication area or it has chosen to ignore your request.

A '**Group Call**' is used to contact a group of vessels that are using the same Group MMSI. All ships in the group who receive the Group call will change to the specified channel. For example, this feature could be used to alert all yachts in a race to announce a change in the race conditions. Any number with a leading zero can be used as a Group MMSI, and they do not need to be registered, but the entity deciding

on a Group MMSI must use the MID of the host country or country of vessel registration (503 in Australia). The Group ID should be based on a key vessel in the Group, and the recommended system is to drop the last digit of the key vessel's MMSI and place a zero in front. e.g. a fleet of vessels that has a lead vessel with a DSC self-ID of 503080110 could use the Group MMSI of 050308011. This would then be programmed into all fleet vessels as the special event Group MMSI.

The 'Test Call' option can be used to make a test call to your local Coast Station. The coast station should provide an automated response to confirm that your radio's DSC is operating correctly.

The operations of the call options described above are very similar.

1. Briefly press the **CALL/MEND** key to enter the DSC menu.
2. Press the **▲** or **▼** keys to select 'Individual Call', 'Position Request', 'Group Call' or 'Test Call' and press **Enter**.
3. You can choose to either manually enter the MMSI of the other radio or recall it from your radio's phone book.

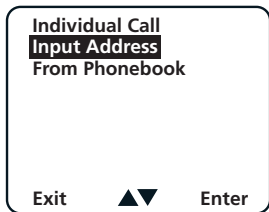

- a. To manually enter the MMSI;
 - i. Select 'Input Address' and press **Enter**.
 - ii. Use the **▲** or **▼** keys to select the number in the flashing digit position then press **▶** to move to the next digit.
 - iii. Repeat to enter all 9 digits of the MMSI number then press **Enter**.

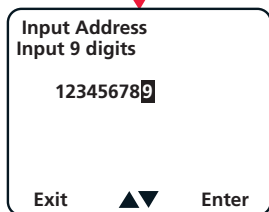
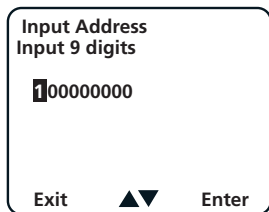

- b. To recall the other radio's MMSI from the phone book;
 - i. Select 'From Phonebook' and press **Enter**.
 - ii. Use the **▲** or **▼** keys to select the name from the list then press **Enter**.



INDIVIDUAL
CALL



POSITION
REQUEST

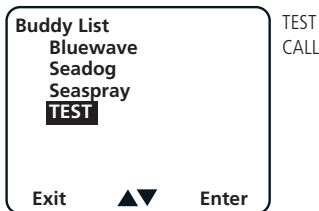
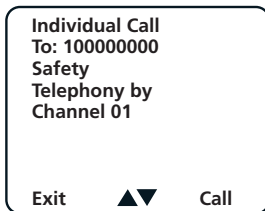

ALL SHIPS CALL

An All Ships Call allows your radio to establish contact with all the other ships in your area without needing to enter their MMSI. All Ships calls are classified as ROUTINE, SAFETY or URGENCY. URGENCY calls (similar to a PAN PAN call) may be sent when a vessel is not in immediate distress but has a problem that may lead to a distress situation. SAFETY calls (similar to SECURITY calls) may be sent when safety information needs to be transmitted to other vessels.

4. For Individual Calls, select from 'Routine', 'Safety' or 'Urgency' and press **Enter**.

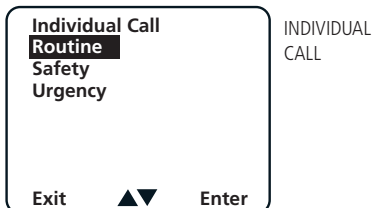

To send an All Ships Call;

- Briefly press the **CALL MENU** key to enter the DSC menu.
- Press the **▲** or **▼** keys to select 'All Ship Call' and press **Enter**.

5. For Individual and Group Calls select a suitable channel from the list provided then press **Enter**.

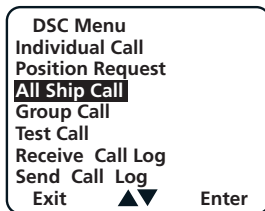
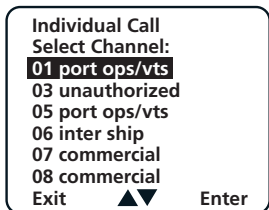

6. A summary of your selected options are displayed. If everything is correct press **Call** to call or **Exit** to cancel.

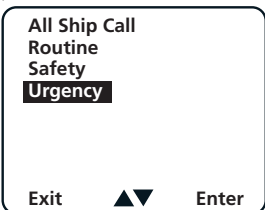

4. Select the required channel.

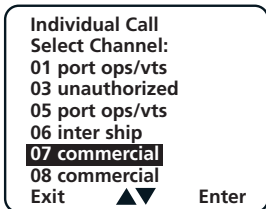

5. A summary of your selected call options is displayed. If everything is correct press **Call** to call or **Exit** to cancel.

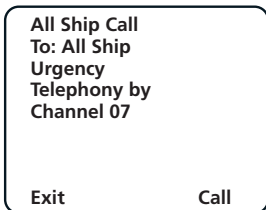

RECEIVE CALL LOG

All incoming DSC calls are logged allowing you to review past messages. To review these messages;

1. Briefly press the **CALL MENU** key to enter the DSC menu.
2. Press the **▲** or **▼** keys to select 'Receive Call Log' and press **Enter**.

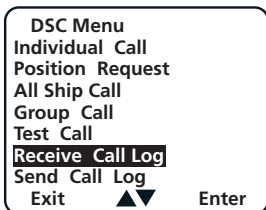

3. Select from 'Distress Call' or 'Others Call' and press **Enter** to display logged calls.

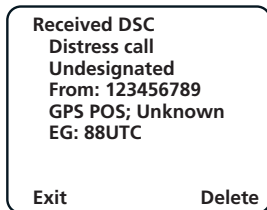
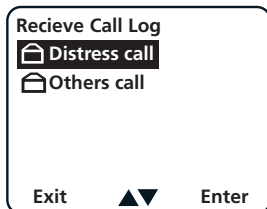

4. Press **Delete** to delete the logged call or press **Exit** to return to the previous page.

SEND CALL LOG

All outgoing DSC calls are logged. To view your outgoing messages;

1. Briefly press the **CALL MENU** key to enter the DSC menu.
2. Press the **▲** or **▼** keys to select 'Send Call Log' and press **Enter**.

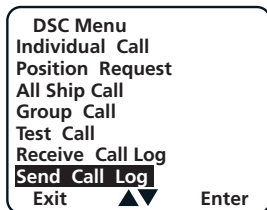

3. Select from 'Distress Call', 'MOB Call' or 'Others Call' and press **Enter** to display your outgoing calls.
4. Select from 'Distress Call', 'MOB Call' or 'Others Call' and press **Enter** to display your outgoing calls.

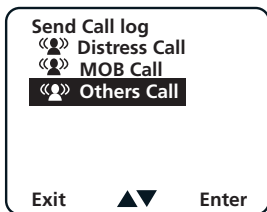

PHONE BOOK

The Phone Book provides access to your stored MMSI's. Normal MMSI's for ships or coast stations can be stored in the Buddy List while Group MMSI's can be stored in the Group List.

To add an MMSI

1. Briefly press the **CALL MENU** key to enter the DSC menu.
2. Press the **▲** or **▼** keys to select 'Phone Book' and press **Enter**.

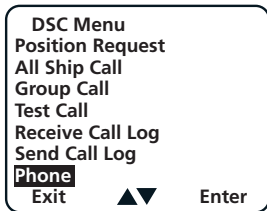

3. Select from 'Buddy List' or 'Group List' and press **Enter**.

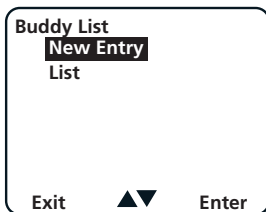
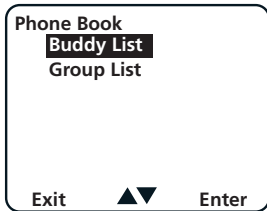

4. Select 'New Entry' to add a new MMSI (or select 'List' to see your current list of stored MMSI's).

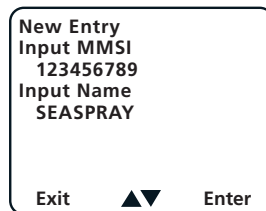
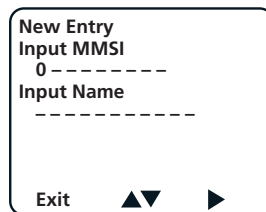

5. Use the **▲** or **▼** keys to select the number in the first digit position then press **▶**.
6. Repeat step 5 to enter the full 9 digit MMSI number then press **Enter**.
7. Repeat step 5 to enter the name of the vessel then press **Enter** to save it.

To View, Edit or List the saved MSSIs

1. Select 'List' and press **Enter**.
2. Select the required ship's name and press **Enter**.

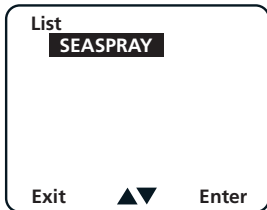
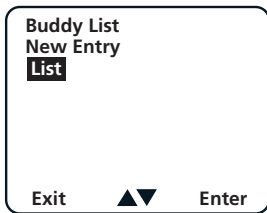

3. Select **View** to view the selected entry, **Edit** to change the entry or **Delete** to remove the entry from the Phone Book.

DSC SETUP

Use the DSC Setup menu to set the default operation of the DSC feature in your radio.

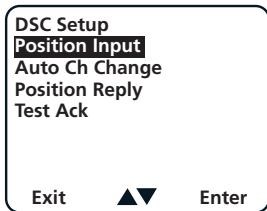

Position Input

The Position Input allows you to manually enter a position in Latitude and Longitude and a time in UTC.

Auto Channel Change

The Auto Channel Change option will determine whether your radio will change channels automatically when requested by another radio. Generally this should be set to Automatic as the DSC system is designed to guide to you a specific channel after receiving a DSC call. However there may be times when this is not desirable, in which case set this feature to Manual.

Position Reply

Position Reply determines whether your radio will respond automatically to a 'Position Request'. If set to Automatic, your radio will automatically respond to a Position Request by transmitting your location back to the caller.

If you do not wish to allow other radios to request your position, set this option to Manual.

Test Acknowledge

Test Acknowledge determines if your radio will respond automatically to a Test call. Test calls sent to a coast station or to another ship can be used to check if the DSC function on your radio is working correctly. If set to Automatic, a Test call sent to your User MMSI will cause your radio to automatically respond to the caller allowing them to confirm their radio is operating correctly.

To disable the Test Acknowledge feature, set this to Manual.

MAIN MENU OPTIONS

To access the Main Menu, press and hold the **CALL/SEND** key. Use the **▲** or **▼** keys to select the required option then press **Enter**.

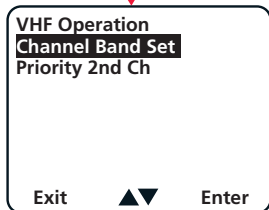
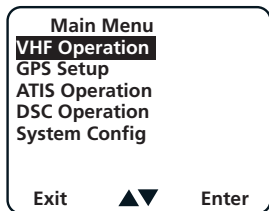

Channel Band Set

Select 'Channel band Set' to set the frequency band for your country of operation. The following options are available;

USA United States of America

INT International (inc. Australia and NZ)

CAN Canada

Use the ▲ or ▼ keys to select the required band then press **Enter** (or select **Exit** to exit without any change).

Priority 2nd Channel

Select 'Priority 2nd Channel' to select the alternate priority channel on the  key.

Use the ▲ or ▼ keys to select the required channel then press **Enter**. The chosen channel will be displayed. Press **Enter** again to save or select **Exit** to exit without any change.

To access the second priority channel press and hold the  key. 'P – 2nd' is displayed and the channel changes to your 2nd priority channel.

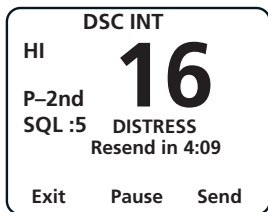

GPS SETUP

GPS Setting

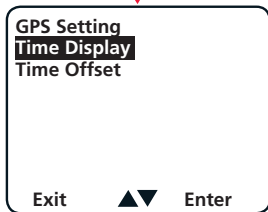
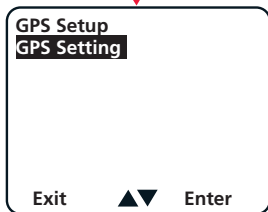
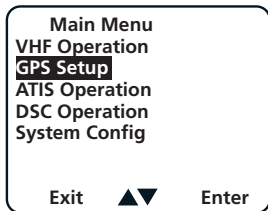







Time Display

Select 'Enable' to display the time and date on the LCD.

Time Offset

The GPS time is normally displayed in UTC (Greenwich Mean Time) by default. To display the time in local time, set the UTC time offset in hours and minutes. e.g. for Sydney Australia set the time offset to UTC +10:00

To set the time,

1. Use the  or  keys to set the + or – offset then press . Set + for locations that are ahead of UTC (East) or – for locations that are behind UTC (West).
2. Use the  or  keys to set the hours minutes and seconds, pressing the  to move to each digit.
3. When the correct time is set press **Enter**.

ATIS OPERATION

ATIS stands for Automatic Transmitter Identification System and is generally used in the inland waterways of Europe. ATIS is used to identify a ship or vessel that has made a radio transmission. The identity of the vessel is sent digitally immediately after the ship's radio operator ceases talking and releases their radio's PTT switch. The ATIS system is similar to the DSC system except that DSC transmissions take place exclusively on Channel 70 whereas the ATIS digital signal is transmitted on the same VHF channel as the voice transmission.

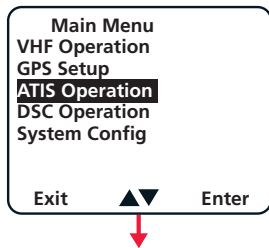

ATIS Operation

My ATIS ID

ATIS Function

Exit





Enter

MY ATIS ID

The use of ATIS requires a unique Maritime Mobile Service Identity or MMSI. The ATIS MMSI is completely separate to the MSSI required for the DSC functionality. Radio operators in Europe should obtain their unique ATIS MMSI from their local Maritime Authority.

To enter the ATIS MMSI

1. Select 'ATIS Operation' from the main Menu and press **Enter**.
2. Select 'My ATIS ID' and press **Enter**.
3. The first digit of the ATIS ID always starts with 9 and cannot be changed. Use the  or  keys to select the required digit in the next character position then press .
4. Repeat step 3 to enter the full 10 digit ATIS MMSI number.
5. Once all 10 digits have been entered, press **Enter**. You will then be asked to enter them again.
6. Repeat step 3 to re-enter the ATIS MMSI then press **Enter** to store or **Exit** to cancel without saving.

ATIS Function

To enable or disable the ATIS operation, select the 'ATIS' Function from the main Menu, then select 'Enable' or 'Disable'. If you choose 'Enable', you will be asked 'Are you sure?' Select **Yes** or **No**.

When the ATIS Function is enabled, your ATIS MMSI will be attached to the end of your transmissions allowing your vessel to be identified whenever you transmit.

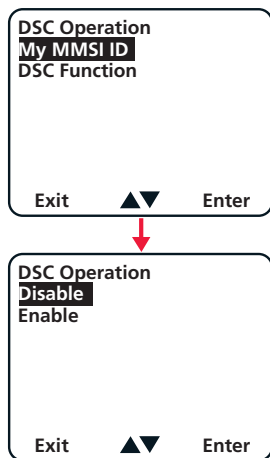

MY MMSI ID

This option duplicates the 'My MMSI ID' option in the DSC menu. Either option can be used to set the User MMSI in the GX850.

DSC Function

Selecting 'DSC Function' allows the DSC feature to be completely disabled on the radio. When the DSC function is disabled, the DSC Menu normally accessed via the Menu key is no longer available.

To enable or disable the DSC Function

1. Select DSC Function in the DSC Operation Menu.
2. Select **Enable** or **Disable**. You will be asked 'Are you sure'.
3. Select **Yes** or **No**.

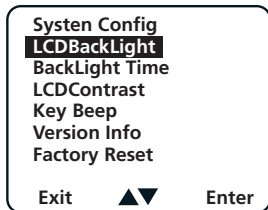

LCD BACKLIGHT

Select 'LCD Backlight' to adjust the brightness of the display backlight. The brightness can be adjusted from 0 (min) to 9 (max). Use the key to increase the brightness or the key to decrease the brightness.

Press **Enter** to accept or **Exit** to cancel.

BACKLIGHT TIME

Select 'Backlight Time' to adjust the length of time (in seconds) before the backlight extinguishes after a key press. The time can be adjusted from 0 (no backlight) to 9 seconds. Use the key to increase the time or the key to decrease the time.

LCD CONTRAST

Select 'LCD Contrast' to adjust the contrast of the display. The contrast can be adjusted from 0 (min) to 9 (max). Use the key to increase the contrast or the key to decrease the contrast.

KEY BEEP

Select 'Key Beep' to set the volume of the beeps that will be heard when a key is pressed. Choose from Off, Quiet, Middle or Loud then press **Enter**. The new Beep volume setting will be applied and a 'tick' will appear adjacent to the selected setting. Once the preferred setting is ticked, press **Exit** to return to the Menu.

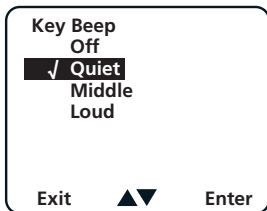

VERSION INFO

Select 'Version Info' to review the software versions installed inside your radio.

FACTORY RESET

Select Factory Reset to clear any settings you have made to your radio and restore it to the factory defaults.

CHARGING THE BATTERY

The battery is a built-in design and is not user serviceable. If the battery requires replacing, the radio should be returned to GME for service to ensure the waterproof integrity of the radio is maintained.

To charge the battery

Unscrew the centre knob on the top panel (between the Volume knob and the antenna). Plug the supplied AC adaptor into the 240V power then connect the adaptor's charger plug into the socket on the top of the radio. Secure it by tightening the collar on the plug.



1. UNSCREW THE CONNECTOR CAP



2. INSERT THE CHARGER PLUG



3. ROTATE THE COLLAR TO SECURE THE PLUG

While the charger is connected the display will show the battery charging state by animating the battery icon.



When the radio is on, the battery symbol animates in the corner of the display.

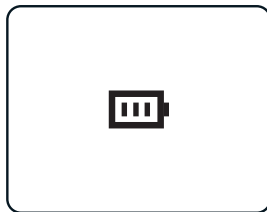

When the radio is switched off, the battery symbol animates in the centre of the display.

INTERNATIONAL MARINE VHF CHANNEL AND FREQUENCIES

CH	TX Freq	RX Freq	Simplex	Use
01	156.050	160.650		Public Correspondence, Port Operations and Ship Movement
02	156.100	160.700		Public Correspondence, Port Operations and Ship Movement
03	156.150	160.750		Public Correspondence, Port Operations and Ship Movement
04	156.200	160.800		Public Correspondence, Port Operations and Ship Movement
05	156.250	160.850		Public Correspondence, Port Operations and Ship Movement
06	156.300	156.300	X	Intership 1
07	156.350	160.950		Public Correspondence, Port Operations and Ship Movement
08	156.400	156.400	X	Intership
09	156.450	156.450	X	Intership, Port Operations and Ship Movement
10	156.500	156.500	X	Intership, Port Operations and Ship Movement 2
11	156.550	156.550	X	Port Operations and Ship Movement
12	156.600	156.600	X	Port Operations and Ship Movement
13	156.650	156.650	X	Intership Safety, Port Operations and Ship Movement 3
14	156.700	156.700	X	Port Operations and Ship Movement
15	156.750	156.750	X	Intership and On-board Communications at 1W only 4
16	156.800	156.800	X	Distress, Safety and Calling
17	156.850	156.850	X	Intership and On-board Communications at 1W only 4
18	156.900	161.500		Public Correspondence, Port Operations and Ship Movement
19	156.950	161.550		Public Correspondence, Port Operations and Ship Movement
20	157.000	161.600		Public Correspondence, Port Operations and Ship Movement
21	157.050	161.650		Public Correspondence, Port Operations and Ship Movement
22	157.100	161.700		Public Correspondence, Port Operations and Ship Movement
23	157.150	161.750		Public Correspondence, Port Operations and Ship Movement
24	157.200	161.800		Public Correspondence, Port Operations and Ship Movement
25	157.250	161.850		Public Correspondence, Port Operations and Ship Movement
26	157.300	161.900		Public Correspondence, Port Operations and Ship Movement
27	157.350	161.950		Public Correspondence, Port Operations and Ship Movement
28	157.400	162.000		Public Correspondence, Port Operations and Ship Movement
60	156.025	160.625		Public Correspondence, Port Operations and Ship Movement
61	156.075	160.675		Public Correspondence, Port Operations and Ship Movement
62	156.125	160.725		Public Correspondence, Port Operations and Ship Movement
63	156.175	160.775		Public Correspondence, Port Operations and Ship Movement
64	156.225	160.825		Public Correspondence, Port Operations and Ship Movement

INTERNATIONAL MARINE VHF CHANNEL AND FREQUENCIES cont.

CH	TX Freq	RX Freq	Simplex	Use
65	156.275	160.875		Public Correspondence, Port Operations and Ship Movement
66	156.325	160.925		Public Correspondence, Port Operations and Ship Movement
67	156.375	156.375	X	Intership, Port Operations and Ship Movement 2
68	156.425	156.425	X	Port Operations and Ship Movement
69	156.475	156.475	X	Intership, Port Operations and Ship Movement
71	156.575	156.575	X	Port Operations and Ship Movement
72	156.625	156.625	X	Intership
73	156.675	156.675	X	Intership 2
74	156.725	156.725	X	Port operations and Ship Movement
75	156.775	156.775	X	See Note 5
76	156.825	156.825	X	See Note 5
77	156.875	156.875	X	Intership
78	156.925	161.525		Public Correspondence, Port Operations and Ship Movement
79	156.975	161.575		Public Correspondence, Port Operations and Ship Movement
80	157.025	161.625		Public Correspondence, Port Operations and Ship Movement
81	157.075	161.675		Public Correspondence, Port Operations and Ship Movement
82	157.125	161.725		Public Correspondence, Port Operations and Ship Movement
83	157.175	161.775		Public Correspondence, Port Operations and Ship Movement
84	157.225	161.825		Public Correspondence, Port Operations and Ship Movement
85	157.275	161.875		Public Correspondence, Port Operations and Ship Movement
86	157.325	161.925		Public Correspondence, Port Operations and Ship Movement
87	157.375	157.375	X	Port Operations and Ship Movement
88	157.425	157.425	X	Port Operations and Ship Movement

Intership channels are for communications between ship stations. Intership communications should be restricted to Channels 6, 8, 72 and 77. If these are not available, the other channels marked for Intership may be used. Channel 70 is used exclusively for Digital Selective Calling (DSC) and is not available for regular voice communications.

NOTES

- Channel 06 may also be used for communications between ship stations and aircraft engaged in coordinated search and rescue operations. Ship stations should avoid harmful interference to such communications on channel 06 as well as to communications between aircraft stations, ice breakers and assisted ships during ice seasons.
- Within the European Maritime Area and in Canada, channels 10, 67 and 73 may also be used by the individual administrations

concerned for communication between ship stations, aircraft stations and participating land stations engaged in coordinated search and rescue and anti-pollution operations in local areas. Channels 10 or 73 (depending on location) are also used for the broadcast of Marine Safety Information by the Maritime and Coast Guard Agency in the UK only.

- Channel 13 is designated for use on a worldwide basis as a navigation safety communication channel, primarily for intership navigation safety communications.
- Channels 15 and 17 may also be used for on-board communications provided the effective radiated power does not exceed 1 watt.
- The use of Channels 75 and 76 should be restricted to navigation related communication only and all precautions should be taken to avoid harmful interference to channel 16. Transmit power is limited to 1 watt.

U.S. MARINE VHF CHANNELS AND FREQUENCIES

CH	TX Freq	RX Freq	Simplex	Use
01A	156.050	156.050	X	Port Operations and Commercial, VTS. Available only in New Orleans / Lower Mississippi area.
05A	156.250	156.250	X	Port Operations or VTS in the Houston, New Orleans and Seattle areas
06	156.300	156.300	X	Intership Safety
07A	156.350	156.350	X	Commercial
08	156.400	156.400	X	Commercial (Intership only)
09	156.450	156.450	X	Boater Calling. Commercial and Non-Commercial
10	156.500	156.500	X	Commercial
11	156.550	156.550	X	Commercial. VTS in selected areas
12	156.600	156.600	X	Port Operations. VTS in selected areas
13	156.650	156.650	X	Intership Navigation Safety (Bridge-to-bridge). Ships >20m length maintain a listening watch on this channel in US waters.
14	156.700	156.700	X	Port Operations. VTS in selected areas
15	--	156.750		Environmental (Receive only). Used by Class C EPIRBs
16	156.800	156.800	X	International Distress, Safety and Calling. Ships required to carry radio, USCG, and most coast stations maintain a listening watch on this channel.
17	156.850	156.850	X	State & local govt maritime control
18A	156.900	156.900	X	Commercial
19A	156.950	156.950	X	Commercial
20	157.000	161.600		Port Operations (duplex)
20A	157.000	157.000	X	Port Operations
21A	157.050	157.050	X	U.S. Coast Guard only
22A	157.100	157.100	X	Coast Guard Liaison and Maritime Safety Information Broadcasts. Broadcasts announced on channel 16.
23A	157.150	157.150	X	U.S. Coast Guard only
24	157.200	161.800		Public Correspondence (Marine Operator)
25	157.250	161.850		Public Correspondence (Marine Operator)
26	157.300	161.900		Public Correspondence (Marine Operator)
27	157.350	161.950		Public Correspondence (Marine Operator)
28	157.400	162.000		Public Correspondence (Marine Operator)

U.S. MARINE VHF CHANNELS AND FREQUENCIES cont.

CH	TX Freq	RX Freq	Simplex	Use
63A	156.175	156.175	X	Port Operations and Commercial, VTS. Available only in New Orleans / Lower Mississippi area.
65A	156.275	156.275	X	Port Operations
66A	156.325	156.325	X	Port Operations
67	156.375	156.375	X	Commercial. Used for Bridge-to-bridge communications in Lower Mississippi River. Intership only.
68	156.425	156.425	X	Non-Commercial
69	156.475	156.475	X	Non-Commercial
70	156.525	156.525	X	Digital Selective Calling (voice communications not allowed)
71	156.575	156.575	X	Non-Commercial
72	156.625	156.625	X	Non-Commercial (Intership only)
73	156.675	156.675	X	Port Operations
74	156.725	156.725	X	Port Operations
77	156.875	156.875	X	Port Operations (Intership only)
78A	156.925	156.925	X	Non-Commercial
79A	156.975	156.975	X	Commercial. Non-Commercial in Great Lakes only
80A	157.025	157.025	X	Commercial. Non-Commercial in Great Lakes only
81A	157.075	157.075	X	U.S. Government only - Environmental protection operations.
82A	157.125	157.125	X	U.S. Government only
83A	157.175	157.175	X	U.S. Coast Guard only
84	157.225	161.825		Public Correspondence (Marine Operator)
85	157.275	161.875		Public Correspondence (Marine Operator)
86	157.325	161.925		Public Correspondence (Marine Operator)
87	157.375	157.375	X	Public Correspondence (Marine Operator)
88A	157.425	157.425	X	Commercial, Intership only

Additional Information, Frequencies, and Charts.

Frequencies are in MHz. Modulation is 16KF3E or 16KG3E.

Recreational boaters normally use channels listed as Non-Commercial: 68, 69, 71, 72, 78A.

Channel 70 is used exclusively for Digital Selective Calling (DSC) and is not available for regular voice communications.

Channels 75 and 76 are reserved as guard bands for Channel 16 and are not available for regular voice communications.

Note that the letter A indicates simplex use of the ship station transmit side of an international duplex channel, and that operations are different than international operations on that channel.

NOAA Weather Channels	
WX1	162.550
WX2	162.400
WX3	162.475
WX4	162.425
WX5	162.450
WX6	162.500
WX7	162.525

Channel numbers, e.g. (WX1, WX2) etc. have no special significance but are often designated this way in consumer equipment. Other channel numbering schemes are also prevalent.

The order of channels shown is the order they were established and is slowly becoming less popular over time than a numerical ordering of channels.

See NATIONAL WEATHER SERVICE MARINE PRODUCTS VIA NOAA WEATHER RADIO and the NOAA Weather Radio Homepage for more information.

Some VHF transceivers are equipped with an International – U.S. switch for that purpose. A channels are generally only used in the United States, and use is normally not recognized or allowed outside the U.S. The letter B indicates simplex use of the coast station transmit side of an international duplex channel. The U.S. does not currently use B channels for simplex communications in this band.

Boaters should normally use channels listed as Non-Commercial. Channel 16 is used for calling other stations or for distress alerting. Channel 13 should be used to contact a ship when there is danger of collision. All ships of length 20m or greater are required to guard VHF channel 13, in addition to VHF channel 16, when operating within U.S. territorial waters. Users may be fined by the FCC for improper use of these channels.

CANADIAN MARINE VHF CHANNELS AND FREQUENCIES

CH	TX Freq	RX Freq	EC	NL	AC	GL	WC	BCC	INL BCC	INL PRA	Use	Restrictions
01	156.050	156.650						X			PC	None
02	156.100	160.700						X			PC	None
03	156.150	160.750						X	X		PC	None
04A	156.200	156.200	X					X			IS, SS, C, S	DFO/Canadian Coast Guard only in BCC area. Commercial fishing in EC area.
05A	156.250	156.250	X	X	X	X	X	X	X		SM	None
06	156.300	156.300	X	X	X	X	X	X	X	X	IS, C, NC, S	May be used for search and rescue communications between ships and aircraft.
07A	156.350	156.350	X	X	X	X	X	X	X		IS, SS, C	None
08	156.400	156.400	X				X		X		IS, C, S	Also assigned for intership in the Lake Winnipeg area.
09	156.450	156.450			X			X		X	IS, SS, C, NC, S, SM	Commercial – BCC area. May be used to communicate with aircraft and helicopters in predominantly maritime support operations.
10	156.500	156.500			X	X		X			IS, SS, C, NC, S, SM	Commercial – BCC area. May also be used for communications with aircraft engaged in coordinated search and rescue and antipollution operations.
11	156.550	156.550			X	X		X			IS, SS, C, NC, SM	VTS – BCC area. Also used for pilotage purposes.
12	156.600	156.600			X	X	X	X			IS, SS, C, NC, SM	VTS – BCC area. Port operations and pilot information and messages.
13	156.650	156.650	X	X	X	X	X	X	X		IS, C, NC, SM	VTS – BCC area. Bridge-to-bridge navigational traffic.
14	156.700	156.700			X	X		X			IS, SS, C, NC, SM	VTS – BCC area. Port operations and pilot information and messages.
15	156.750	156.750	X	X	X	X	X	X	X	X	IS, SS, C,	Port operations and Ship Movement – BCC area. All operations limited to 1 watt maximum power. May also be used for on-board communications.
16	156.800	156.800									All areas	

CANADIAN MARINE VHF CHANNELS AND FREQUENCIES cont.

CH	TX Freq	RX Freq	EC	NL	AC	GL	WC	BCC	INL BCC	INL PRA	Use	Restrictions
17	156.850	156.850	X	X	X	X	X	X	X	X	IS, SS, C, NC, SM	Port operations and Ship Movement – BCC area. All operations limited to 1 watt maximum power. May also be used for on board communications. maximum power. May also be used for on board communications.
18A	156.900	156.900	X	X	X	X	X	X	X		IS, SS, C	Towing – BCC area
19A	156.950	156.950	X	X	X	X	X	X	X	X	IS, SS	DFO/Canadian Coast Guard. Pacific Pilots – BCC area.
20	157.000	161.600	X	X	X	X	X	X	X		SS, S, SM	Port operations only with 1 watt maximum power.
21A	157.050	157.050	X	X	X	X	X	X	X	X	IS, SS	DFO/Canadian Coast Guard only
21B	-----	161.650	X	X	X	X	X	X	X	X	S	Continuous Marine Broadcast (CMB) service.
22A	157.100	157.100	X	X	X	X	X	X	X	X	IS, SS, C, NC	For communications between Canadian Coast Guard and non-Canadian Coast Guard stations only.
23	157.150	161.750						X	X		SS, PC	None
23B	-----	161.750				X					S	Continuous Marine Broadcast (CMB) service
24	157.200	161.800	X	X	X	X	X	X	X	X	SS, PC	None
25	157.250	161.850						X			SS, PC	Also assigned for operations in the Lake Winnipeg area.
25B	-----	161.850			X						S	Continuous Marine Broadcast (CMB) service
26	157.300	161.900	X	X	X	X	X	X	X	X	SS, PC	None
27	157.350	161.950			X	X		X			SS, PC	None
28	157.400	162.000						X			SS, S, PC	None
28B	-----	162.000			X	X					S	Continuous Marine Broadcast (CMB) service
60	156.025	160.625						X			SS, PC	None
61A	156.075	156.075	X					X			IS, SS, C	DFO/Canadian Coast Guard only in BCC area. Commercial fishing only in EC area.
62A	156.125	156.125	X					X			IS, SS, C	DFO/Canadian Coast Guard only in BCC area. Commercial fishing only in EC area.
63A	156.175	156.175						X			IS, SS, C	Tow Boats – BCC area
64	156.225	160.825						X			SS, PC	None

CANADIAN MARINE VHF CHANNELS AND FREQUENCIES cont.

CH	TX Freq	RX Freq	EC	NL	AC	GL	WC	BCC	INL BCC	INL PRA	Use	Restrictions
64A	156.225	156.225	X								IS, SS, C	Commercial fishing only
65A	156.275	156.275	X	X	X	X	X	X	X	X	S, IS, SS, C, NC	Search and rescue and antipollution operations on the Great Lakes. Towing on the Pacific Coast. Port operations only in the St. Lawrence River areas with 1 watt maximum power. Intership in INLD PRA.
66A	156.950	156.950	X	X	X	X	X	X	X		IS, SS	Port operations only in the St. Lawrence River/Great Lakes areas with 1-watt maximum power. 1 watt marina channel – BCC area.
67	156.375	156.375	X	X	X	X	X	X	X	X	SS, IS, C, NC	May also be used for communications with aircraft engaged in coordinated search and rescue and antipollution operations. Commercial fishing only in EC and INLD PRA areas. Pleasure craft – BCC area.
68	156.425	156.425	X	X	X	X	X	X	X	X	IS, SS, NC	For marinas, yacht clubs and pleasure craft.
69	156.475	156.475	X	X	X	X	X	X	X		IS, SS, C, NC	Commercial fishing only – EC area. Pleasure craft – BCC area.
70	156.525	156.525	Digital Selective Calling for Distress, Urgency, Safety and Calling								All Areas	Voice communications prohibited.
71	156.575	156.575	X	X	X	X	X	X	X		S, IS, SS, SM, C, NC	Ship Movement – BCC area. Marinas and yacht clubs – EC and on Lake Winnipeg.
72	156.625	156.625	X					X			IS, C, NC	May be used to communicate with aircraft and helicopters in predominantly maritime support operations. Pleasure craft – BCC area.
73	156.675	156.675	X	X	X	X	X	X	X	X	S, IS, SS,	May also be used for communications with aircraft engaged in coordinated search and rescue and antipollution operations. Commercial fishing only in EC and INLD PRA areas.
74	156.725	156.725	X					X			IS, SS, SM, C, NC	VTS and Ship Movement – BCC area
75	156.775	156.775	X	X	X	X	X	X	X	X	IS, SS, SM, C	Simplex port operation, ship movement and navigation related communication only. 1 watt maximum.

CANADIAN MARINE VHF CHANNELS AND FREQUENCIES cont.

CH	TX Freq	RX Freq	EC	NL	AC	GL	WC	BCC	INL BCC	INL PRA	Use	Restrictions
76	156.225	156.225	X								IS, SS, SM, C	Simplex port operation, ship movement and navigation related communication only. 1 watt maximum.
77	156.275	156.275	X	X	X	X	X	X	X	X	S, IS, SS, SM,	Pilotage – BCC area; 25 watts. Port operations only in the St. Lawrence River/Great Lakes areas with 1 watt maximum power.
78A	156.950	156.950	X	X	X	X	X	X	X		IS, SS, C	Fishing Industry – BCC area
79A	156.375	156.375	X	X	X	X	X	X	X	X	SS, IS,	Fishing Industry – BCC area
80A	157.025	157.025	X					X			IS, SS, C	Whale Watching – BCC area
81A	157.075	157.075	X	X	X	X	X	X	X		S, IS, SS	DFO/Canadian Coast Guard use only
82A	157.125	157.125	X	X	X	X	X	X	X		IS, SS	DFO/Canadian Coast Guard use only
83A	157.175	157.175			X	X		X			IS, SS	DFO/Canadian Coast Guard and other Government agencies.
83B	-----	161.775			X	X		X			S	Continuous Marine Broadcast (CMB) Service.
84	157.225	161.825						X			SS, PC	None
85	157.275	161.875		X	X	X		X			SS, PC	None
86	157.325	161.925						X			SS, PC	None
87	157.375	161.375		X	X	X		X			IS, SM, NC	Port operation and ship movement – EC area. Pleasure craft – BCC area.
87B	161.975	161.975	X	X	X	X	X	X	X	X	AIS	Automatic Ship Identification and Surveillance System.
88	157.425	157.425		X	X	X		X			IS, SM, C	Port operation and ship movement – BCC area.
88B	162.025	162.025	X	X	X	X	X	X	X	X	AIS	Automatic Ship Identification and Surveillance System.

WEATHER CHANNELS

WX-1	-----				162.550			S				Environment Canada Weather Radio
WX-2	-----				162.400			S				Environment Canada Weather Radio
WX-3	-----				162.475			S				Environment Canada Weather Radio
WX-4	-----				162.425			S				Environment Canada Weather Radio
WX-5	-----				162.450			S				Environment Canada Weather Radio
WX-6	-----				162.500			S				Environment Canada Weather Radio
WX-7	-----				162.525			S				Environment Canada Weather Radio

Table Footnotes

EC	- East Coast (NL, AC, GL, and Eastern Arctic areas)	IS	Intership
NL	- Newfoundland and Labrador	SS	Ship / Shore
AC	- Atlantic Coast, Gulf and St. Lawrence River to and including Montreal	C	Commercial
GL	- Great Lakes including the St. Lawrence above Montreal	NC	Non-Commercial
WC	- West Coast (BCC, Western Arctic, and Athabasca-Mackenzie Watershed areas)	S	Safety
BCC	- British Columbia Coast (Pacific Coast)	SM	Ship Movement
Inland BC	- Inland Waters of BC and the Yukon	PC	Public Correspondence
Inland PRA	- Inland Waters of MB, SK, and AB	AIS	Automatic Ship Identification
		VTS	Vessel Traffic Services

SPECIFICATIONS

GENERAL	RECEIVER
Frequency Range: 156.025 to 162.425 MHz	Sensitivity (12dB SINAD): -119 dBm
Number of Channels: 56 International 52 USA 59 Canadian 10 Weather	Squelch: Threshold: -119 dBm Tight: -113 dBm to -107 dBm Hysteresis: 3~6 dB Attack Time: <50 ms Delay Time: <250 ms
Oscillator: PLL	Rated Audio Output @5% THD Speaker: 250 mW
Modulation: FM	Adjacent Channel Rejection: > 70 dB
Channel Spacing: 25 kHz	Image Rejection: > 70 dB
Frequency Stability: ±5 PPM	Intermodulation Rejection: > 68 dB
Digital Selective Calling (DSC): Class D (EN301025)	Spurious Response rejection (CH16) 80 MHz to 1 GHz: > 70 dB
Man Over Board (MOB): DSC Channel 70	Conducted Spurious Emission: < 70 dB
Standard Operating Temperature: -20°C ~ +55°C	Scan Time per Channel: 200 ms
Nominal Working Voltage: 7.4 V DC	RX Current: Standby – 185 mA Max Audio Power – 380 mA
Low Voltage Limit: 6.8 V DC	TRANSMITTER
Battery Life (5% TX, 5% RX, 90% Stby): ≥8 Hrs	Output Power: High – 5W Low – 0.8W
Antenna Socket : SMA	Frequency Tolerance: ±2.5 PPM
Built in Speaker: 40 mm Diameter, 8 Ohms	Max Modulation: ± 5 kHz
Dimensions: 67 (W) x 153 (H) x 43 (D) mm	Conducted Spurious Emission: < -56 dB
Battery: 7.4 V 1700 mAh Li-Polymer	Audio Distortion @ 3 kHz Dev: < 5%
DC Charger: 9 V @ 1000 mA	Conducted Spurious Emission: < -56 dB
Charging Current: 760 mA ± 130 mA	TX Current: High Power – 1.6 A Low Power – 0.9 A
GPS Receiver: 48 Channel	<i>Specifications are nominal and are subject to change without notice or obligation</i>
Waterproof: IP67	

This warranty against defects is given by Standard Communications Pty Ltd ACN 000 346 814 (We, us, our or GME). Our contact details are set out in clause 2.7. This warranty statement only applies to products purchased in Australia. Please contact your local GME distributor for products sold outside of Australia. Local distributor details at www.gme.net.au/export.

1. Consumer guarantees

1.1 Our goods come with guarantees that cannot be excluded under the Australian Consumer Law. You are entitled to a replacement or refund for a major failure and for compensation for any other reasonably foreseeable loss or damage. You are also entitled to have the goods repaired or replaced if the goods fail to be of acceptable quality and the failure does not amount to a major failure.

1.2 To the extent we are able; we exclude all other conditions, warranties and obligations which would otherwise be implied.

2. Warranty against defects

2.1 This warranty is in addition to and does not limit, exclude or restrict your rights under the Competition and Consumer Act 2010 (Australia) or any other mandatory protection laws that may apply.

2.2 We warrant our goods to be free from defects in materials and workmanship for the warranty period (see warranty table) from the date of original sale (or another period we agree to in writing). Subject to our obligations under clause 1.2, we will at our option, either repair or replace goods which we are satisfied are defective. We warrant any replacement parts for the remainder of the period of warranty for the goods into which they are incorporated.

2.3 To the extent permitted by law, our sole liability for breach of a condition, warranty or other obligation implied by law is limited.

(a) in the case of goods we supply, to any one of the following as we decide –

(i) the replacement of the goods or the supply of equivalent goods;

(ii) the repair of the goods;

(iii) the cost of repairing the goods or of acquiring equivalent goods;

(b) in the case of services we supply, to any one of the following as we decide -

(i) the supplying of the services again;

(ii) the cost of having the services supplied again.

2.4 For repairs outside the warranty period, we warrant our repairs to be free from defects in materials and workmanship for three months from the date of the original repair. We agree to re-repair or replace (at our option) any materials or workmanship which we are satisfied are defective.

2.5 We warrant that we will perform services with reasonable care and skill and agree to investigate any complaint regarding our services made in good faith. If we are satisfied that the complaint is justified, and as our sole liability to you under this warranty (to the extent permitted at law), we agree to supply those services again at no extra charge to you.

2.6 To make a warranty claim you must before the end of the applicable warranty period (see warranty table), at your own cost, return the goods you allege are defective, provide written details of the defect, and give us an original or copy of the sales invoice or some other evidence showing details of the transaction.

2.7 Send your claim to:

Standard Communications Pty Ltd.
PO Box 96, Winston Hills, NSW 2153, Australia.
Tel: 1300 463 463
Email: servadmin@gme.net.au

2.8 If we determine that your goods are defective, we will pay for the cost of returning the repaired or replaced goods to you, and reimburse you for your reasonable expenses of sending your warranty claim to us.

3. What this warranty does not cover

3.1 This warranty will not apply in relation to:

- (a) goods modified or altered in any way;
- (b) defects and damage caused by use with non Standard Communications products;
- (c) repairs performed other than by our authorised representative;
- (d) defects or damage resulting from misuse, accident, impact or neglect;
- (e) goods improperly installed or used in a manner contrary to the relevant instruction manual; or
- (f) goods where the serial number has been removed or made illegal.

4. Warranty period

4.1 We provide the following warranty on GME and Kingray products. No repair or replacement during the warranty period will renew or extend the warranty period past the period from original date of purchase.

PRODUCT TYPE	WARRANTY PERIOD
GX800/GX850 Marine radios	2 years



gme.net.au

Standard Communications Pty Ltd trading as GME.